

OMEGA® GENERAL SERVICE GAUGES TYPE S

PGS Series

Starts at
£47



PGS-25L-150, £47, shown larger than actual size.



PGS-35L-30, £57, shown larger than actual size.



- ✓ 63 and 89 mm (2½ and 3½") Dials
- ✓ Stem and Panel Mount Styles
- ✓ Weather-Resistant Stainless Steel Case
- ✓ 316 SS Wetted Parts
- ✓ 1% FS Accuracy

To combat hostile environments, this general service gauge is corrosion, weather, and dust resistant. Mounting versatility,

excellent readability, and sustained accuracy make this stainless steel design a gauge leader. It can be stem, surface, or flush mounted.

Sustained accuracy and excellent readability are especially important to users of the OMEGA® general service gauge line. Meeting the

requirements of many industrial applications, general service gauges can be used on steam boilers or other pressurized vessels; on pumps and compressors; on many types of industrial machinery; in the chemical, petrochemical, and allied process industries; in power plants; and in pulp and paper mills.

The pressure gauge actuation system in the OMEGA® general service gauge line is the standard 316 SS Bourdon tube system, which is engineered to precise tolerances for repeatability and consistent response to pressure fluctuations.

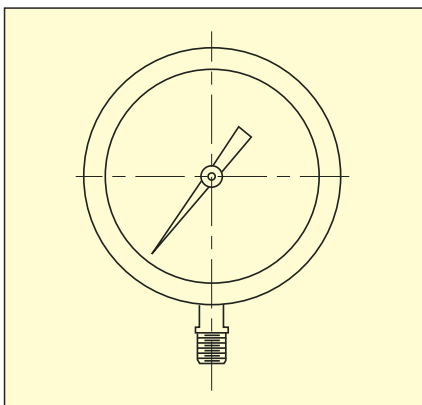

STYLE L

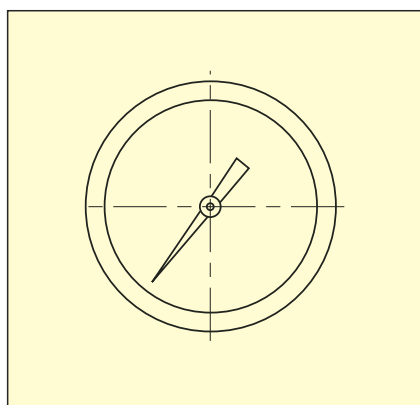

STYLE B

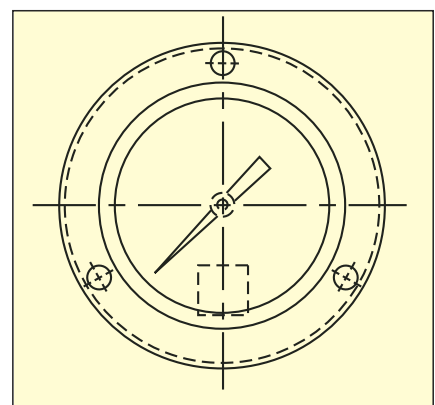

STYLE B
With Flange Mounting Kit

TYPE S GENERAL SERVICE GAUGES

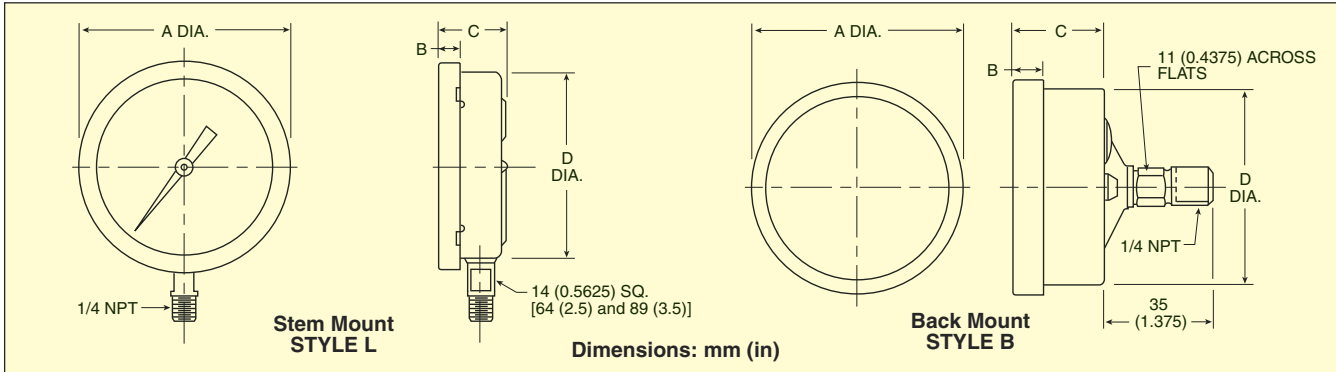

SPECIFICATIONS

Max Operating Temp: 66°C (150°F)

Case: Polished stainless steel

Window: Polycarbonate plastic with Neoprene sealing gasket

Bourdon Tube: 316 SS

Connection: Back or lower

Fitting: 316 SS, 1/4 NPT

Dial Size: 2½ and 3½"

Mounting: Stem, flange or "U" bracket

Accuracy: 1% full scale

Warning: To prevent misapplication, all gauge components should be chosen with an eye to the media and ambient operating conditions to which they will be exposed. Improper application can be detrimental to the gauge, causing failure and possible personal injury and property damage.

ACCESSORIES FOR TYPE S GAUGES

MODEL NO.	DESCRIPTION	PRICE
UBK-25	U-bracket kit for 2½ gauge	£6.70
UBK-35	U-bracket kit for 3½ gauge	8
FMK-25	Flange mount kit for 2½ gauge	10
FMK-35	Flange mount kit for 3½ gauge	13.50

Dimensions: mm (in)

SIZE INCHES	A	B	C	D
2½	73 (2 ⁷ / ₈)	10 (³ / ₈)	29 (1 ⁵ / ₃₂)	67 (2 ²¹ / ₃₂)
3½	101 (3 ³¹ / ₃₂)	12 (¹⁵ / ₃₂)	31 (1 ⁷ / ₃₂)	91 (3 ¹⁹ / ₃₂)

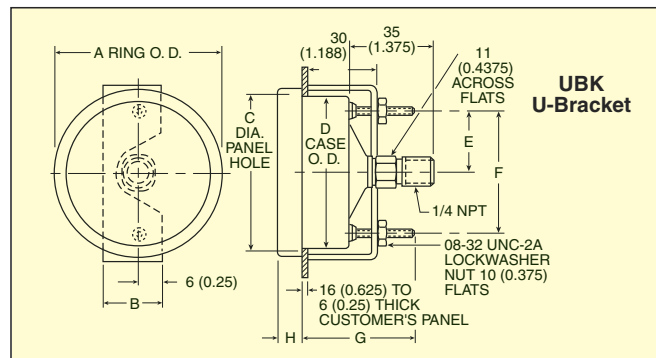
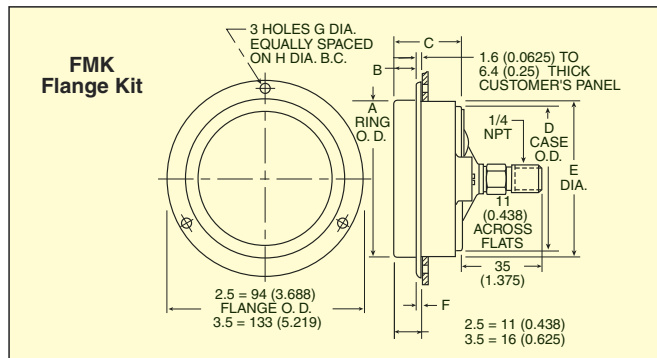

Dimensions: mm (in)

SIZE INCHES	A	B	C	D	E	F	G	H
2½	73 (2 ⁷ / ₈)	10 (³ / ₈)	29 (1 ⁵ / ₃₂)	67 (2 ²¹ / ₃₂)	69 (2 ²³ / ₃₂)	2 (¹ / ₁₆)	4 (⁵ / ₃₂)	79 (3 ¹ / ₈)
3½	101 (3 ³¹ / ₃₂)	12 (¹⁵ / ₃₂)	31 (1 ⁷ / ₃₂)	91 (3 ¹⁹ / ₃₂)	94 (3 ¹¹ / ₁₆)	4 (⁵ / ₃₂)	6 (⁷ / ₃₂)	116 (4 ⁹ / ₁₆)

Dimensions: mm (in)

SIZE INCHES	A	B	C	D	E	F	G	H
2½	73 (2 ⁷ / ₈)	29 (1 ¹ / ₈)	68 (2 ¹¹ / ₁₆)	67 (2 ²¹ / ₃₂)	26 (1 ¹ / ₃₂)	52 (2 ¹ / ₁₆)	45 (1 ²⁵ / ₃₂)	10 (³ / ₈)
3½	101 (3 ³¹ / ₃₂)	27 (1 ¹ / ₁₆)	93 (3 ²¹ / ₃₂)	91 (3 ¹⁹ / ₃₂)	31 (1 ⁷ / ₃₂)	61 (2 ¹³ / ₃₂)	44 (1 ³ / ₄)	12 (¹⁵ / ₃₂)

HOW TO ORDER TYPE S GENERAL SERVICE GAUGES

Standard Ranges—Type S Pressure (psi)



DIAL SIZE	MODEL NO.	CONNECTION	PRICE
2½"	PGS-25L-[*] (to 600 psi)	Lower	£47
	PGS-25L-[*] (over 600 psi)	Lower	54
	PGS-25B-[*] (to 600 psi)	Back	57
	PGS-25B-[*] (over 600 psi)	Back	60
3½"	PGS-35L-[*] (to 600 psi)	Lower	57
	PGS-35L-[*] (over 600 psi)	Lower	64
	PGS-35B-[*] (to 600 psi)	Back	64
	PGS-35B-[*] (over 600 psi)	Back	74

* Insert range code from table below. Comes with complete operator's manual.

Option: "X6B", oxygen service cleaning, £43.50.

Ordering Example: PGS-25B-160, pressure gauge, general service type, 2½" dial, back connection, 0/160 psi range, £57.



PGS-25L-30, \$70, shown smaller than actual size.

Pressure Range: Select a gauge with a full scale pressure range of approximately twice the normal operating pressure. The maximum operating pressure should not exceed approximately 75% of the full scale range. Failure to select a gauge range within these criteria may ultimately result in fatigue failure of the Bourdon tube.

Oil-Filled Gauges Also Available: Type S gauges are available on special order filled with silicone oil. The silicone oil is used to dampen the internal movement of the gauge when it is installed on vibrating equipment. The oil has an operating range of -40 to 66°C (-40 to 150°F). The maximum storage temperature of the gauge is 82°C (180°F).

To Order: Add suffix "F" to model number and an additional \$25 to price for 2½" gauges or an additional £23.50 for 3½" gauges.



PGS-25L-150, £47, shown smaller than actual size.

MOST POPULAR MODELS HIGHLIGHTED!

RANGE CODE	RANGE	FIGURE INTERVAL	MINOR GRADUATION
15	0/15	1	0.2
30	0/30	5	0.5
60	0/60	5	1
100	0/100	10	1
160	0/160	20	2
200	0/200	20	2
300	0/300	30	5
400	0/400	50	6
600	0/600	50	10
800	0/800	100	10
1000	0/1000	100	10
1500	0/1500	200	20
2000	0/2000	200	20
3000	0/3000	300	50
5000	0/5000	500	50
6000	0/6000	1000	100
7500	0/7500	1000	100
10,000	0/10,000	1000	100
VACUUM			
30V	30 to 0 inHg	5 inHg	0.5 inHg

RANGE CODE	RANGE	FIGURE INTERVAL		MINOR GRADUATION	
		INCHES MERCURY	psi	INCHES MERCURY	psi
30V/15	30 inHg vac/0/15 psi	5	3	1	0.5
30V/30	30 inHg vac/0/30 psi	10	5	1	1
30V/60	30 inHg vac/0/60 psi	10	10	2	1
30V/100	30 inHg vac/0/100 psi	10	10	2	1
30V/150	30 inHg vac/0/150 psi	10	20	5	2
30V/300	30 inHg vac/0/300 psi	30	25	5	5

Note: For Type S gauges with oxygen cleaning, gauge fill must be Halocarbon. Add £16.75

Ordering Example: PGS-25B-60-F, pressure gauge, general service type, 2½" dial, 0/60 psi range, silicone oil filled, £57 + 16.75 = £73.75.

ACCESSORY

MODEL NO.	PRICE	DESCRIPTION
CM-4422	£27	Reference Book: Hydraulics and Pneumatics





UNITED STATES

www.omega.com

1-800-TC-OMEGA

Stamford, CT.

CANADA

www.omega.ca

Laval(Quebec)

1-800-TC-OMEGA

GERMANY

www.omega.de

Deckenpfronn, Germany

0800-8266342

UNITED KINGDOM

www.omega.co.uk

Manchester, England

0800-488-488

FRANCE

www.omega.fr

088-466-342

CZECH REPUBLIC

www.omegaeng.cz

Karviná, Czech Republic

596-311-899

BENELUX

www.omega.nl

0800-099-33-44



More than 100,000 Products Available!

• Temperature

Calibrators, Connectors, General Test and Measurement Instruments, Handheld Instruments for Temperature Measurement, Ice Point References, Indicating Labels, Crayons, Cements and Lacquers, Infrared Temperature Measurement Instruments, Recorders, Relative Humidity Measurement Instruments, PT100 Probes, PT100 Elements, Temperature & Process Meters, Timers and Counters, Temperature and Process Controllers and Power Switching Devices, Thermistor Elements, Probes and Assemblies, Thermocouples, Thermowells and Head and Well Assemblies, Transmitters, Thermocouple Wire, RTD Probes

• Flow and Level

Air Velocity Indicators, Doppler Flowmeters, Level Measurement, Magnetic Flowmeters, Mass Flowmeters, Pitot Tubes, Pumps, Rotameters, Turbine and Paddle Wheel Flowmeters, Ultrasonic Flowmeters, Valves, Variable Area Flowmeters, Vortex Shedding Flowmeters

• pH and Conductivity

Conductivity Instrumentation, Dissolved Oxygen Instrumentation, Environmental Instrumentation, pH Electrodes and Instruments, Water and Soil Analysis Instrumentation

• Data Acquisition

Auto-Dialers and Alarm Monitoring Systems, Communication Products and Converters, Data Acquisition and Analysis Software, Data Loggers Plug-in Cards, Signal Conditioners, USB, RS232, RS485 and Parallel Port Data Acquisition Systems, Wireless Transmitters and Receivers

• Pressure, Strain and Force

Displacement Transducers, Dynamic Measurement Force Sensors, Instrumentation for Pressure and Strain Measurements, Load Cells, Pressure Gauges, Pressure Reference Section, Pressure Switches, Pressure Transducers, Proximity Transducers, Regulators, Pressure Transmitters, Strain Gauges, Torque Transducers, Valves

• Heaters

Band Heaters, Cartridge Heaters, Circulation Heaters, Comfort Heaters, Controllers, Meters and Switching Devices, Flexible Heaters, General Test and Measurement Instruments, Heater Hook-up Wire, Heating Cable Systems, Immersion Heaters, Process Air and Duct, Heaters, Radiant Heaters, Strip Heaters, Tubular Heaters