

# ELECTRONIC MASS FLOWMETERS

## Flow Reference Section



FMA-2100 Series  
(from \$494)

Shown Smaller  
Than Actual Size

FMA-3300 series  
(from \$399), see  
page D-14



FMA-1700/FMA-1800  
series (from \$431),  
see page D-15

### INTRODUCTION

The continuing need for improved accuracy in flow measurement of mass related processes such as chemical reactions and thermal transfers has resulted in the development of electronic mass flowmeters. Thermal-type mass flowmeters operate with minor dependence on density, pressure, and fluid viscosity. This style of flowmeter utilizes a heated sensing element and thermodynamic heat conduction principles to determine the true mass flow rate.

### Understanding Mass Flow

To understand the mass flow concept, it is essential to begin with the relationship between mass, temperature and pressure. Real gases roughly follow the ideal gas law, which states that the pressure, temperature and volume of a gas are all interrelated.

$PV = nRT$ , where:

P = pressure of the gas  
V = volume that the gas occupies  
n = number of molecules (*i.e.*, mass)  
R = ideal gas constant  
T = temperature of the gas

The ideal gas law defines the volume a certain mass of gas will occupy under specific conditions. For example, say a fixed mass of gas occupies a one liter container at 70°F under 1 atmosphere pressure. When the pressure of the system is increased (with the temperature held constant), the volume will decrease. If the temperature is increased, (with the volume held constant), the pressure will increase. The only constant variable is the mass of the gas; it does not change.

Mass flow is the molecular measurement of the gas flowrate. This is usually measured in units of mass per unit of time, as kilograms per hour. However, gas flow is usually measured in volume, such as liters per hour, but, since volume is dependent upon temperature and pressure, it is

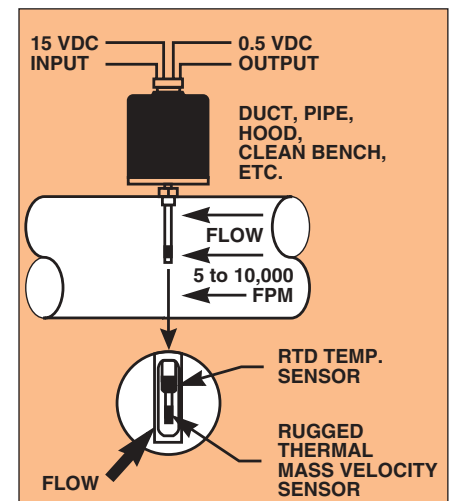

Figure 1: Insertion style mass flow sensor utilizes RTD sensor to measure the flow rate

therefore necessary to adopt standard temperature and pressure conditions before one can define volumetric flow rate. Usually, these conditions are specified as 70°F and 1 atmosphere (14.7 psia) pressure. Using these standards, it is possible to take an exact mass flow and

reference it to more traditional measures without losing accuracy. For example, a 500 lb. per hour flow of nitrogen can be translated into standard cubic feet per minute (SCFM) units using the following relationship:

$$Q_s = \dot{m}/(\rho)_s$$

where:

$(\rho)_s$  = density of the gas at standard conditions

$\dot{m}$  = mass flow rate

$Q_s$  = standard mass flow rate (e.g., SCFM)

In many applications, only the volumetric flow rate referenced to the actual pipe conditions is known.

To convert actual cubic feet per minute (ACFM) to standard conditions (SCFM), the following relationship is used:

$$Q_s = Q_a \times (P_a/P_s) \times (T_s/T_a)$$

where:

$P_a$  = actual pressure

$P_s$  = standard pressure

$T_s$  = standard temperature

$T_a$  = actual temperature conditions

$Q_a$  = actual mass flow rate (e.g., ACFM)

For example, to determine the standard flowrate of a gas at 100°F

and 100 psig, flowing at 100 ACFM:

$$Q_s = 100 \text{ ACFM} \times \frac{(100 \text{ psig} + 14.7 \text{ psia})}{(14.7 \text{ psia})} \times \frac{(529.4 \text{ R})}{(459.4 + 100^\circ\text{F})}$$

## OPERATING PRINCIPLE

Electronic mass flowmeters and flow controllers employ thermodynamic principles to measure true mass flow rate without the need for temperature or pressure compensation. The following is a brief description of the two operating principles employed: heated tube and immersed probe.

### Heated Tube

#### FMA-A2000, FMA-1700/1800, FMA-3300 Series Flowmeters

In these units, all or part of the gas flow passes through a precision-manufactured sensing tube (Fig. 2). Heat (Q) is applied to the gas flowing through the sensor tube via two externally wound resistance temperature detectors ( $T_1$  and  $T_2$ ). The detectors have a dual function: to both heat and sense the sensor-tube temperature. When the molecules of the gas pass through the upstream sensor winding ( $T_1$ ) they carry away a certain amount of heat.

This process is repeated at the downstream sensor winding ( $T_2$ ) but less heat is transferred from the downstream sensor winding due to the flow's having been preheated by the first sensor. The temperature differential ( $T_2 - T_1$ ) between the two sensors in a Wheatstone bridge circuit is measured. Since the temperature difference between the two sensors is directly proportional to the mass flow of the gas (m), a highly accurate and repeatable flow measurement is obtained.

Electronic mass flowmeters are not affected by pressure or temperature changes over the specified range of the unit.

Also, heated tube mass flowmeters can accommodate virtually any clean gas. If the flow range remains the same, a correlation factor (K) is typically used to relate the calibration of nitrogen to the actual gas. This K factor is derived experimentally or from the gas density and coefficient of specific heat:

$$K = (\rho)C_p$$

where:

$\rho$  = gas density (g/liter)

$C_p$  = coefficient of specific heat (cal/gram °C)

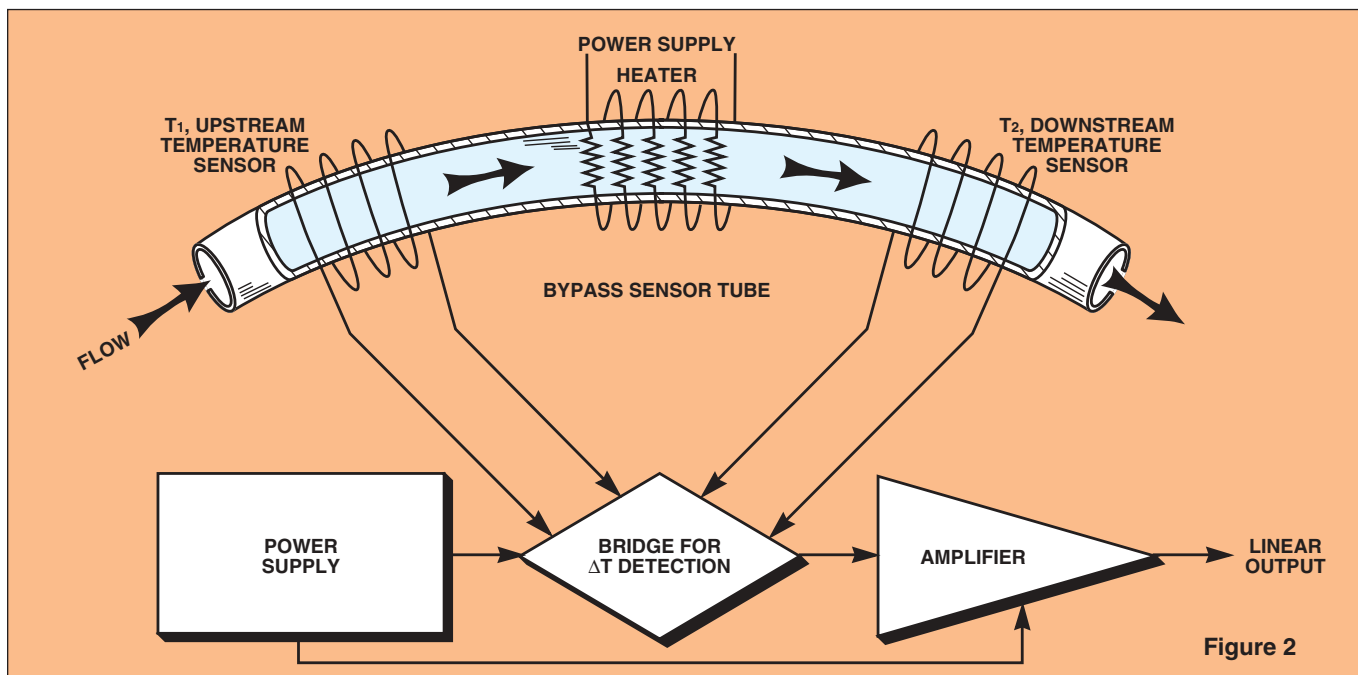

Figure 2

# ELECTRONIC MASS FLOWMETERS

## Flow Reference Section

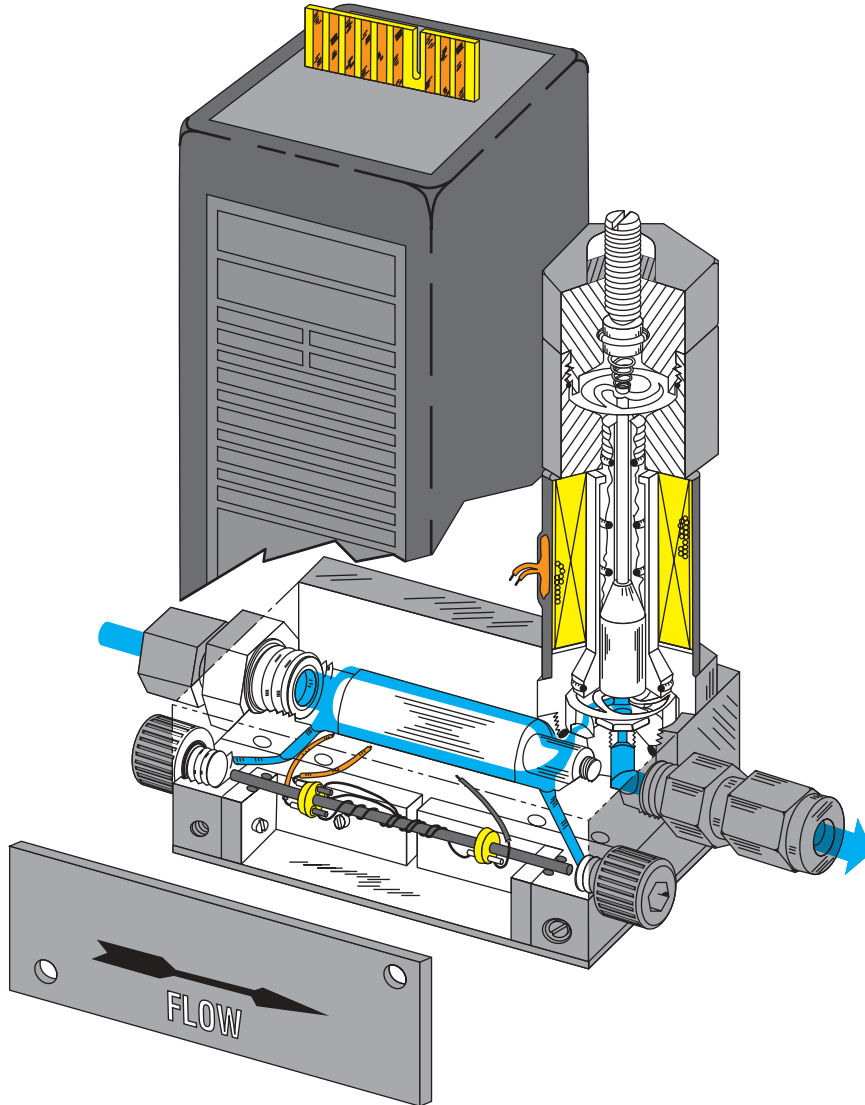

Figure 3: Heated tube mass flow controller

The flowrate of a reference gas (subscript “r”) and that of an actual gas (subscript “a”) are related as follows:

$$Q_a = (K_r/K_a)Q_r = \frac{(\rho_r C_{p_r}) Q_r}{(\rho_a C_{p_a})}$$

Where:

Q = mass flow rate in SCCM

Note that, in the above relationship, ( $\rho$ ) and  $C_p$  are usually established under standard conditions.

For example, to determine the flow rate of carbon dioxide ( $CO_2$ ) when the flowmeter is calibrated in nitrogen at 100 SCCM, the conversion equation is

$$Q_{CO_2} = \frac{\rho_{N_2}}{\rho_{CO_2}} \times \frac{C_{p_{N_2}}}{C_{p_{CO_2}}} \times Q_{N_2}$$

$$= \frac{1.16 \times 0.249}{1.84 \times 0.204} \times 100 = 77.0 \text{ SCCM}$$

A partial listing of correction factors for different gases is provided on page D-22. Consult Engineering for other factors.

Flexibility, easy maintenance, and excellent low-flow sensitivity are the major benefits of heated tube mass flowmeters. The addition of an electromagnetically controlled automatic valve turns the meter into a mass flow controller, ideal for any application where mass (as opposed to volumetric) flowrate control is desired.

The only requirement for this type flowmeter is that the fluid should be very clean (*e.g.*, bottled gases), since the design makes these units very sensitive to dirt particles. For flows with any particulates present, the immersed probe style mass flowmeter should be considered.

### Immersion Probe Style

These units consist of a thermal mass flow probe and integral electronics for a linearized analog output (usually 0-5 Vdc, or 4-20 mA). The probe itself consists of two temperature-sensitive RTD (resistance temperature detector sensors). Both are constructed of reference grade platinum, coated

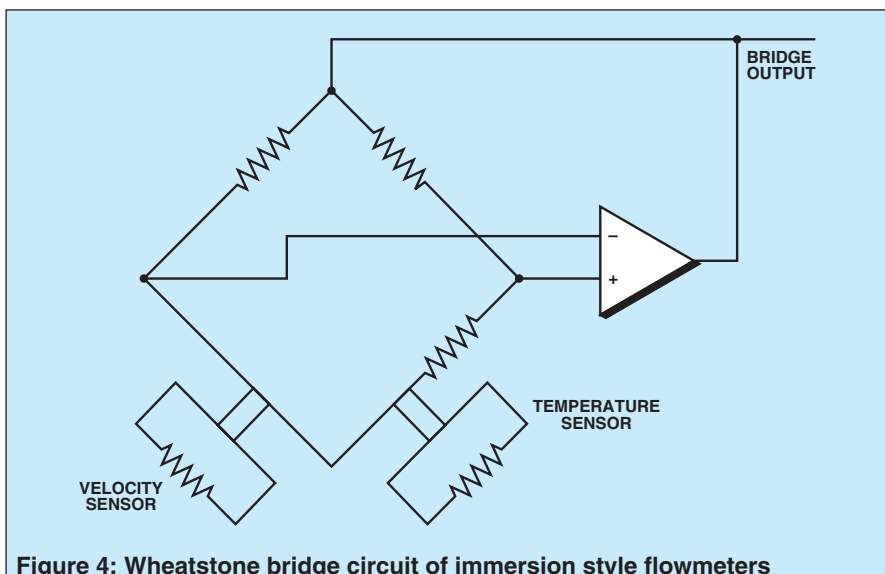
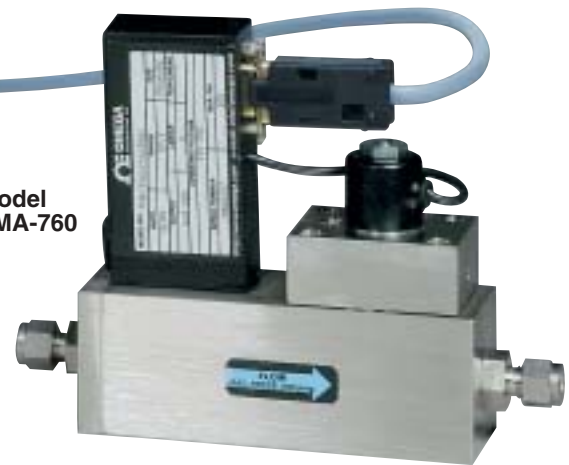

Figure 4: Wheatstone bridge circuit of immersion style flowmeters



Model FMA-78P4 Readout/Power Supply Electronics (page D-8)



Model FMA-78C10  
8 ft. interconnecting cable  
sold separately (page D-8)

Figure 5: Non-symmetrical and symmetrical flow profiles

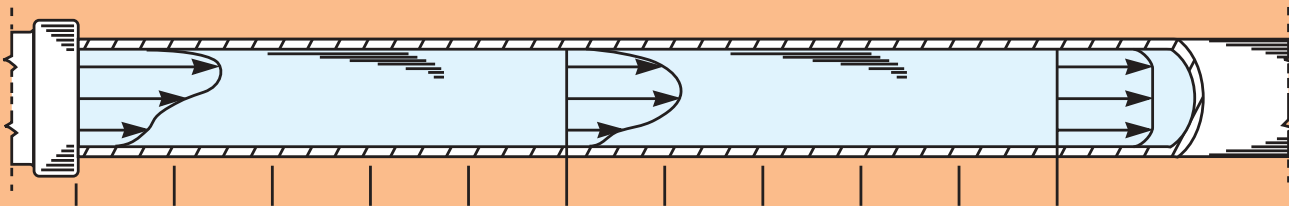

with glass. These sensors are large, rugged, insensitive to dirt, and easily cleaned. The first sensor constantly measures the ambient temperature of the gas flow and maintains the operational temperature differential of the second sensor. If the temperature of the flow varies, the first sensor detects and references it, providing a temperature-compensated basis for measurement.

The second sensor is the flow detection sensor, and is heated to a temperature 60°F higher than the first. As the gas flows past, a certain amount of heat is transferred from the heated sensor to the gas. The heat transfer rate is proportional to the mass velocity of the gas, or  $(\rho)V$ . It is this principle of heat transfer from the sensor to the gas that is the key to the immersion-style probe. When the flow of gas passing over the flow sensor increases, the sensor loses more heat to the gas. As it loses heat, more current is needed to maintain the 60°F temperature differential between the two sensors. The two

sensors operate together as part of a Wheatstone forced null bridge circuit (Fig. 4). The output signal of the sensor is the bridge voltage (or current) required to maintain the constant temperature differential, which is non-linearly proportional to the mass velocity  $(\rho)V$ . The non-linear output of the bridge circuit is then linearized and converted to a standard analog output signal by the integrally mounted electronics.

### Special Consideration for Insertion Probes

OMEGA® FMA Series air velocity transducers measure air mass velocity. Mass velocity is velocity weighed by the gas density  $(\rho)V$ . The fundamental units of  $\rho(V)$  are  $\text{lb-m/ft}^3 \times \text{ft/min}$ , or  $\text{lb-m/ft}^2/\text{min}$ , but, normally,  $\rho(V)$  is referred to in terms of standard feet per minute (SFPM), where the standard reference conditions are 25°C and 1 atmosphere pressure. To convert from SFPM to standard cubic feet per minute (SCFM), multiply the standard velocity in SFPM by the cross sectional pipe area. (For pipe

cross sectional area, see page Z-27). To convert from SCFM to actual cubic feet per minute, refer to the equation for converting from actual to standardized flowrate.

FMA Series air velocity transducers measure the air mass velocity at the location of the flow sensor. The point of measurement can be critical if flows are not uniform or flat. If a duct does not have a uniform flow, point measurements will not be the same throughout (see Fig. 5). Flow in a straight duct or pipe will usually be symmetrical and relatively uniform if the ratio of straight pipe length to pipe diameter is at least 10 to 1 and the duct walls are relatively smooth. For example, 10 diameters in a 6" diameter pipe is 60". Tees, elbows, valves and other flow obstructions will cause irregularities in the flow until they have a sufficient length of straight pipe to become more uniform. If a straight section of duct greater than 10 diameters in length is unavailable, other approaches may be employed as outlined in the instruction manual provided with the unit.



#### UNITED STATES

[www.omega.com](http://www.omega.com)  
1-800-TC-OMEGA  
Stamford, CT.

#### CANADA

[www.omega.ca](http://www.omega.ca)  
Laval(Quebec)  
1-800-TC-OMEGA

#### GERMANY

[www.omega.de](http://www.omega.de)  
Deckenpfronn, Germany  
0800-8266342

#### UNITED KINGDOM

[www.omega.co.uk](http://www.omega.co.uk)  
Manchester, England  
0800-488-488

#### FRANCE

[www.omega.fr](http://www.omega.fr)  
Guyancourt, France  
088-466-342

#### CZECH REPUBLIC

[www.omegaeng.cz](http://www.omegaeng.cz)  
Karviná, Czech Republic  
596-311-899

#### BENELUX

[www.omega.nl](http://www.omega.nl)  
Amstelveen, NL  
0800-099-33-44



## More than 100,000 Products Available!

### • Temperature

Calibrators, Connectors, General Test and Measurement Instruments, Glass Bulb Thermometers, Handheld Instruments for Temperature Measurement, Ice Point References, Indicating Labels, Crayons, Cements and Lacquers, Infrared Temperature Measurement Instruments, Recorders Relative Humidity Measurement Instruments, RTD Probes, Elements and Assemblies, Temperature & Process Meters, Timers and Counters, Temperature and Process Controllers and Power Switching Devices, Thermistor Elements, Probes and Assemblies, Thermocouples Thermowells and Head and Well Assemblies, Transmitters, Wire

### • Flow and Level

Air Velocity Indicators, Doppler Flowmeters, Level Measurement, Magnetic Flowmeters, Mass Flowmeters, Pitot Tubes, Pumps, Rotameters, Turbine and Paddle Wheel Flowmeters, Ultrasonic Flowmeters, Valves, Variable Area Flowmeters, Vortex Shedding Flowmeters

### • pH and Conductivity

Conductivity Instrumentation, Dissolved Oxygen Instrumentation, Environmental Instrumentation, pH Electrodes and Instruments, Water and Soil Analysis Instrumentation

### • Data Acquisition

Auto-Dialers and Alarm Monitoring Systems, Communication Products and Converters, Data Acquisition and Analysis Software, Data Loggers Plug-in Cards, Signal Conditioners, USB, RS232, RS485 and Parallel Port Data Acquisition Systems, Wireless Transmitters and Receivers

### • Pressure, Strain and Force

Displacement Transducers, Dynamic Measurement Force Sensors, Instrumentation for Pressure and Strain Measurements, Load Cells, Pressure Gauges, Pressure Reference Section, Pressure Switches, Pressure Transducers, Proximity Transducers, Regulators, Strain Gages, Torque Transducers, Valves

### • Heaters

Band Heaters, Cartridge Heaters, Circulation Heaters, Comfort Heaters, Controllers, Meters and Switching Devices, Flexible Heaters, General Test and Measurement Instruments, Heater Hook-up Wire, Heating Cable Systems, Immersion Heaters, Process Air and Duct, Heaters, Radiant Heaters, Strip Heaters, Tubular Heaters