

# POSITIONING STRAIN GAGES TO MONITOR BENDING, AXIAL, SHEAR, AND TORSIONAL LOADS

In the glossary to the Pressure Reference Section, "strain" is defined as the ratio of the change in length to the initial unstressed reference length. A strain gage is the element that senses this change and converts it into an electrical signal. This can be accomplished because a strain gage changes resistance as it is stretched, or compressed, similar to wire. For example, when wire is stretched, its cross-sectional area decreases; therefore, its resistance increases.

The important factors that must be considered before selecting a strain gage are the direction, type, and resolution of the strain you wish to measure.

To measure minute strains, the user must be able to measure minute resistance changes. The Wheatstone Bridge configuration, shown in Figure B, is capable of measuring these small resistance changes. Note the signs associated with each gage numbered 1 through 4. The total strain is always the sum of the four strains.

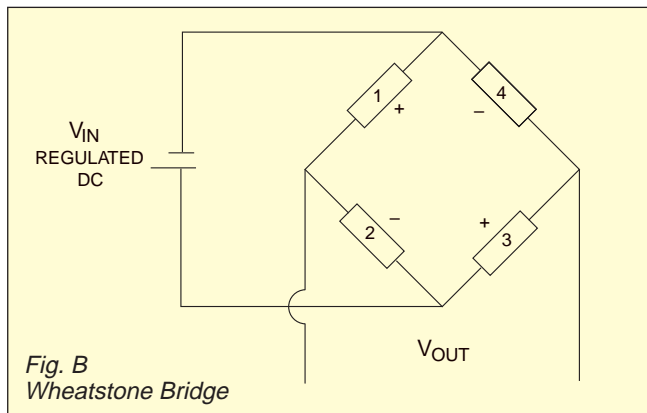

The total strain is represented by a change in  $V_{OUT}$ . If each gage had the same positive strain, the total would be zero and  $V_{OUT}$  would remain unchanged. Bending, axial, and shear strain are the most common types of strain measured. The actual arrangement of your strain gages will determine the type of strain you can measure and the output voltage change. See Figures C through F.

For example, if a positive (tensile) strain is applied to gages 1 and 3, and a negative (compressive) strain to gages 2 and 4, the total strain

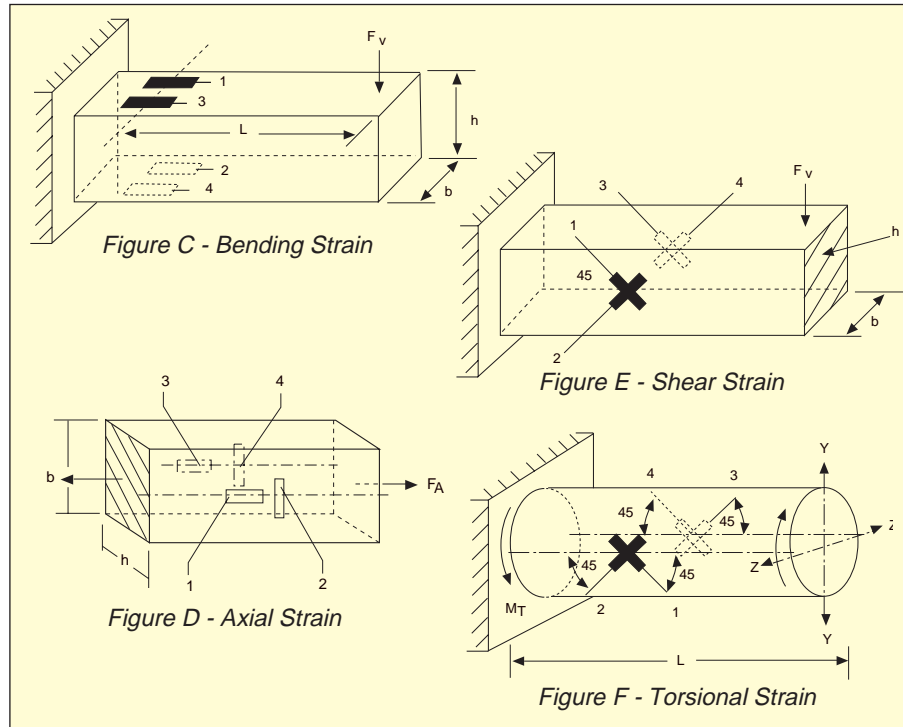

would be 4 times the strain on one gage. See Figure C.

If total strain is four times the strain on one gage, this means that the output will be four times larger. Therefore, greater sensitivity and resolution are possible when more than one strain gage is used.

The following equations show the relationships

among stress, strain, and force for bending, axial, shear, and torsional strain.

- BENDING STRAIN** or moment strain is equal to bending stress divided by Young's Modulus of Elasticity.

$$\epsilon_B = \sigma_B / E \quad \sigma_B = M_B / Z = F_V(\cdot) / Z$$

Moment stress ( $\sigma_B$ ) equals bending moment ( $F_V \times \cdot$ ) divided by sectional modulus. Sectional modulus ( $Z$ ) is a property of the cross-sectional configuration of the specimen. For rectangles only, the

sectional modulus is  $(bh^2/6)$ . Strain gages used in the bending strain configuration can be used to determine vertical load ( $F_V$ ); this is more commonly referred to as a bending beam load cell.

$$F_V = E \epsilon_B(Z) // = E \epsilon_B(bh^2/6) //$$

- AXIAL STRAIN** equals axial stress divided by Young's Modulus.

$$E_A = \sigma_A / E \quad \sigma_A = F_A / A$$

Where axial stress ( $\sigma_A$ ) equals the axial load divided by the cross-sectional area. The cross-sectional area for rectangles equals  $(b \times d)$ . Therefore, strain gages used in axial configurations can be used to determine axial loads ( $F$  (axial)).

$$F \text{ (axial)} = E \epsilon_A bh$$

- SHEAR STRAIN** equals shear stress divided by modulus of shear stress.

$$\gamma = \tau / G \quad \tau = F_V \times Q / bl$$

Where shear stress ( $\tau$ ) equals ( $Q$ ), the moment of area about the neutral axis multiplied by the vertical load ( $F_V$ ) divided by the thickness ( $b$ ) and the moment of

# POSITIONING STRAIN GAGES TO MONITOR BENDING, AXIAL, SHEAR, AND TORSIONAL LOADS

inertia (I). Both the moment of area (Q) and the moment of inertia (I) are functions of the specimen's cross-sectional geometry.

For rectangles only  
 $Q = bh\frac{2}{3}$  and  $I = bh\frac{3}{12}$

The shear strain ( $\gamma$ ) is determined by measuring the strain at a 45° angle, as shown in Figure E.

$$\gamma = 2 \times \epsilon @ 45^\circ$$

The modulus of shear strain (G) =  $E/2(1 + \mu)$ . Therefore, strain gages used in a shear strain configuration can be used to determine vertical loads ( $F_V$ ); this is more commonly referred to as a shear beam load cell.

$$\begin{aligned} F_V &= G(\gamma) bI/Q \\ &= G(\gamma) b(bh\frac{2}{3})/(bh\frac{3}{12}) \\ &= G(\gamma)bh(2/3) \end{aligned}$$

- 4) **TORSIONAL STRAIN** equals torsional stress ( $\tau$ ) divided by torsional modulus of elasticity (G). See Figure F.

$$\begin{aligned} \gamma &= 2 \times \epsilon @ 45^\circ = \tau/G \\ \tau &= M_t(d/2)/J \end{aligned}$$

where torsional stress ( $\tau$ ) equals torque ( $M_t$ ) multiplied by the distance from the center of the section to the outer fiber ( $d/2$ ), divided by (J), the polar moment of inertia. The polar moment of inertia is a function of the cross-sectional area. For solid circular shafts only,  $J = \pi(d)^4/32$ . The modulus of shear strain (G) has been defined in the preceding discussion on shear stress. Strain gages can be used to determine torsional moments as shown in the equation below. This represents the principle behind every torque sensor.

$$\begin{aligned} M_t &= \tau(J) (2/d) \\ &= \gamma G (J) (2/d) \\ &= \gamma G (\pi d^3/6) \\ \emptyset &= M_t L/G(J) \end{aligned}$$

a gage factor of 2.0, Poisson's Ratio of 0.3, and it disregards the lead wire resistance.

This chart is quite useful in determining the meter sensitivity required to read strain values.

Temperature compensation is achieved in many of the above configurations. Temperature compensation means that the gage's thermal expansion coefficient does not have to match the specimen's thermal expansion coefficient; therefore, any OMEGA® strain gage, regardless of its temperature characteristics, can be used with any specimen material. Quarter bridges can have temperature compensation if a dummy gage is used. A dummy gage is a strain gage used in place of a fixed resistor. Temperature compensation is achieved when this dummy gage is mounted on a piece of material similar to the specimen which undergoes the same temperature changes as does the specimen, but which is not exposed to the same strain. Strain temperature compensation is not the same as load (stress) temperature compensation, because Young's Modulus of Elasticity varies with temperature.

The following table shows how bridge configuration affects output, temperature compensation, and compensation of superimposed strains. This table was created using

STRAIN	BRIDGE TYPE	POSITION OF GAGES FIG. C-F	SENSITIVITY mV/V @ 1000 $\mu\epsilon$	OUTPUT PER $\mu\epsilon$ @ 10 V EXCITATION	TEMP. COMP.	SUPERIMPOSED STRAIN COMPENSATED
BENDING	1/4	1	0.5	5 $\mu V/\mu\epsilon$	No	None
	1/2	1, 2	1.0	10 $\mu V/\mu\epsilon$	Yes	Axial
	Full	All	2.0	20 $\mu V/\mu\epsilon$	Yes	Axial
AXIAL	1/4	1	0.5	5 $\mu V/\mu\epsilon$	No	None
	1/2	1, 2	0.65	6.5 $\mu V/\mu\epsilon$	Yes	None
	1/2	1, 3	1.0	10 $\mu V/\mu\epsilon$	No	Bending
	Full	All	1.3	13 $\mu V/\mu\epsilon$	Yes	Bending
SHEAR AND TORSIONAL	1/2	1, 2	1.0	10 $\mu V/\mu\epsilon$ @ 45°F	Yes	Axial and Bending
	Full	All	2.0	20 $\mu V/\mu\epsilon$ @ 45°F	Yes	Axial and Bending

Note: Shear and torsional strain =  $2 \times \epsilon @ 45^\circ$ .



#### UNITED STATES

[www.omega.com](http://www.omega.com)

1-800-TC-OMEGA

Stamford, CT.

#### CANADA

[www.omega.ca](http://www.omega.ca)

Laval(Quebec)

1-800-TC-OMEGA

#### GERMANY

[www.omega.de](http://www.omega.de)

Deckenpfronn, Germany

0800-8266342

#### UNITED KINGDOM

[www.omega.co.uk](http://www.omega.co.uk)

Manchester, England

0800-488-488

#### FRANCE

[www.omega.fr](http://www.omega.fr)

088-466-342

#### CZECH REPUBLIC

[www.omegaeng.cz](http://www.omegaeng.cz)

Karviná, Czech Republic

596-311-899

#### BENELUX

[www.omega.nl](http://www.omega.nl)

0800-099-33-44



## More than 100,000 Products Available!

### • Temperature

Calibrators, Connectors, General Test and Measurement Instruments, Handheld Instruments for Temperature Measurement, Ice Point References, Indicating Labels, Crayons, Cements and Lacquers, Infrared Temperature Measurement Instruments, Recorders, Relative Humidity Measurement Instruments, PT100 Probes, PT100 Elements, Temperature & Process Meters, Timers and Counters, Temperature and Process Controllers and Power Switching Devices, Thermistor Elements, Probes and Assemblies, Thermocouples, Thermowells and Head and Well Assemblies, Transmitters, Thermocouple Wire, RTD Probes

### • Flow and Level

Air Velocity Indicators, Doppler Flowmeters, Level Measurement, Magnetic Flowmeters, Mass Flowmeters, Pitot Tubes, Pumps, Rotameters, Turbine and Paddle Wheel Flowmeters, Ultrasonic Flowmeters, Valves, Variable Area Flowmeters, Vortex Shedding Flowmeters

### • pH and Conductivity

Conductivity Instrumentation, Dissolved Oxygen Instrumentation, Environmental Instrumentation, pH Electrodes and Instruments, Water and Soil Analysis Instrumentation

### • Data Acquisition

Auto-Dialers and Alarm Monitoring Systems, Communication Products and Converters, Data Acquisition and Analysis Software, Data Loggers Plug-in Cards, Signal Conditioners, USB, RS232, RS485 and Parallel Port Data Acquisition Systems, Wireless Transmitters and Receivers

### • Pressure, Strain and Force

Displacement Transducers, Dynamic Measurement Force Sensors, Instrumentation for Pressure and Strain Measurements, Load Cells, Pressure Gauges, Pressure Reference Section, Pressure Switches, Pressure Transducers, Proximity Transducers, Regulators, Pressure Transmitters, Strain Gauges, Torque Transducers, Valves

### • Heaters

Band Heaters, Cartridge Heaters, Circulation Heaters, Comfort Heaters, Controllers, Meters and Switching Devices, Flexible Heaters, General Test and Measurement Instruments, Heater Hook-up Wire, Heating Cable Systems, Immersion Heaters, Process Air and Duct, Heaters, Radiant Heaters, Strip Heaters, Tubular Heaters