

The RS-232 Standard

Information being transferred between data processing equipment and peripherals is in the form of digital data which is transmitted in either a serial or parallel mode. Parallel communications are used mainly for connections between test instruments or computers and printers, while serial is often used between computers and other peripherals.

Serial transmission involves the sending of data one bit at a time, over a single communications line. In contrast, parallel communications require at least as many lines as there are bits in a word being transmitted (for an 8-bit word, a minimum of 8 lines are needed). Serial transmission is beneficial for long distance communications, whereas parallel is designed for short distances or when very high transmission rates are required.

Standards

One of the advantages of a serial system is that it lends itself to transmission over telephone lines. The serial digital data can be converted by modem, placed onto a standard voice-grade telephone line, and converted back to serial digital data at the receiving end of the line by another modem.

Officially, RS-232 is defined as the "Interface between data terminal equipment and data communications equipment using serial binary data exchange." This definition defines data terminal equipment (DTE) as the computer, while data communications equipment (DCE) is the modem. A modem cable has pin-to-pin connections, and is designed to connect a DTE device to a DCE device.

Interfaces

In addition to communications between computer equipment over telephone lines, RS-232 is now widely used for direct connections between data acquisition devices and computer systems. As in the definition of RS-232, the computer is data transmission equipment (DTE). However, many interface products are not data communications equipment (DCE). Null modem cables are designed for this situation; rather than having the pin-to-pin connections of modem cables, null modem cables have different internal wiring to allow DTE devices to communicate with one another.

Cabling Options

RS-232 cables are commonly available with either 4, 9 or 25-pin wiring. The 25-pin cable connects every pin; the 9-pin cables do not include many of the uncommonly used connections; 4-pin cables provide the bare minimum connections, and have jumpers to provide "handshaking" for those devices that require it. These jumpers connect pins 4, 5 and 8, and also pins 6 and 20.

The advent of the IBM PC AT has created a new wrinkle in RS-232 communications. Rather than having the standard 25-pin connector, this computer and many new expansion boards for PC's feature a 9-pin serial port. To connect this port to a standard 25-pin port, a 9-to-25-pin adaptor cable can be utilized, or the user can create his own cable specifically for that purpose.

Selecting a Cable

The major consideration in choosing an RS-232 cable is, what devices are to be connected? First, are you connecting two DTE devices (null modem cable) or a DTE device to a DCE device (modem cable)? Second, what connectors are required on each end, male or female, 25-pin or 9-pin (AT style)? Usually, it is recommended that the user obtain the two devices to be connected, and then determine which cable is required.

RS-232 Specifications

TRANSMITTED SIGNAL VOLTAGE LEVELS:

Binary 0: +5 to +15 Vdc (called a "space" or "on")
Binary 1: -5 to -15 Vdc (called a "mark" or "off")

RECEIVED SIGNAL VOLTAGE LEVELS:

Binary 0: +3 to +13 Vdc
Binary 1: -3 to -13 Vdc

DATA FORMAT:

Start bit: Binary 0
Data: 5, 6, 7 or 8 bits
Parity: Odd, even, mark or space (not used with 8-bit data)
Stop bit: Binary 1, one or two bits

Transmission Example

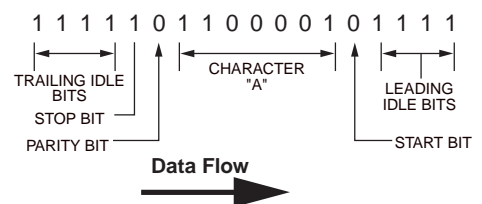

9-Pin "AT" Style

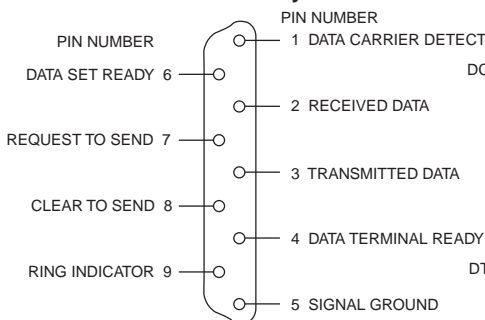

Pin Assignments 25-Pin Style

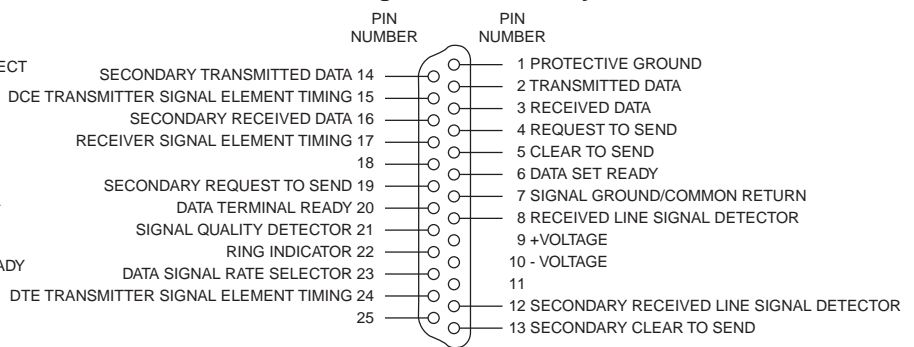



UNITED STATES

www.omega.com

1-800-TC-OMEGA

Stamford, CT.

CANADA

www.omega.ca

Laval(Quebec)

1-800-TC-OMEGA

GERMANY

www.omega.de

Deckenpfronn, Germany

0800-8266342

UNITED KINGDOM

www.omega.co.uk

Manchester, England

0800-488-488

FRANCE

www.omega.fr

088-466-342

CZECH REPUBLIC

www.omegaeng.cz

Karviná, Czech Republic

596-311-899

BENELUX

www.omega.nl

0800-099-33-44



More than 100,000 Products Available!

• Temperature

Calibrators, Connectors, General Test and Measurement Instruments, Handheld Instruments for Temperature Measurement, Ice Point References, Indicating Labels, Crayons, Cements and Lacquers, Infrared Temperature Measurement Instruments, Recorders, Relative Humidity Measurement Instruments, PT100 Probes, PT100 Elements, Temperature & Process Meters, Timers and Counters, Temperature and Process Controllers and Power Switching Devices, Thermistor Elements, Probes and Assemblies, Thermocouples, Thermowells and Head and Well Assemblies, Transmitters, Thermocouple Wire, RTD Probes

• Flow and Level

Air Velocity Indicators, Doppler Flowmeters, Level Measurement, Magnetic Flowmeters, Mass Flowmeters, Pitot Tubes, Pumps, Rotameters, Turbine and Paddle Wheel Flowmeters, Ultrasonic Flowmeters, Valves, Variable Area Flowmeters, Vortex Shedding Flowmeters

• pH and Conductivity

Conductivity Instrumentation, Dissolved Oxygen Instrumentation, Environmental Instrumentation, pH Electrodes and Instruments, Water and Soil Analysis Instrumentation

• Data Acquisition

Auto-Dialers and Alarm Monitoring Systems, Communication Products and Converters, Data Acquisition and Analysis Software, Data Loggers Plug-in Cards, Signal Conditioners, USB, RS232, RS485 and Parallel Port Data Acquisition Systems, Wireless Transmitters and Receivers

• Pressure, Strain and Force

Displacement Transducers, Dynamic Measurement Force Sensors, Instrumentation for Pressure and Strain Measurements, Load Cells, Pressure Gauges, Pressure Reference Section, Pressure Switches, Pressure Transducers, Proximity Transducers, Regulators, Pressure Transmitters, Strain Gauges, Torque Transducers, Valves

• Heaters

Band Heaters, Cartridge Heaters, Circulation Heaters, Comfort Heaters, Controllers, Meters and Switching Devices, Flexible Heaters, General Test and Measurement Instruments, Heater Hook-up Wire, Heating Cable Systems, Immersion Heaters, Process Air and Duct, Heaters, Radiant Heaters, Strip Heaters, Tubular Heaters