

# STEPPER MOTORS

## FRAME SIZES FROM NEMA 11 TO 34



**Wide Range  
of Motor  
Sizes!**

**All models shown  
smaller than actual size.**

OMEGA offers a robust line of 2-phase bipolar step motors ranging in frame size from NEMA 11 to NEMA 34. Most of our models are the high torque style, with holding torques up to 1845 oz-in. All motors conform to industry-standard NEMA mounting dimensions, and are offered with a range of well-featured, compatible drives and indexers. With the exception of our two smallest motors (OMHT11-013, OM5014-842), all of our step motors are optimized for microstepping: they can achieve a stepping resolution of up to 51,200 steps/revolution (0.007° per step) when operated by one of our microstepping drives. In addition, these motors can be operated in a closed-loop system for even more precise position control when fitted with one of our incremental encoders.

8-lead motors offer the flexibility of either series or parallel connection. The motors should be series connected for best torque at low speeds, and parallel connected for best torque at higher speeds.

### Motor Wiring

#### Parallel Connection (8-lead motors):

Drive A+ = Orange + Black/White  
Drive A- = Black + Orange/White  
Drive B+ = Red + Yellow/White  
Drive B- = Yellow + Red/White

#### Series Connection (8-lead motors):

Drive A+ = Orange  
Drive A- = Black  
Drive B+ = Red  
Drive B- = Yellow  
Connect Orange/White to Black/White (not connected to drive)  
Connect Red/White to Yellow/White (not connected to drive)

#### (4-lead motors):

Drive A+ = Red  
Drive A- = Blue  
Drive B+ = Yellow  
Drive B- = White



### MOTION INSTALLATION TIPS

- Mount the motor securely against a surface with good thermal conductivity such as steel or aluminum
- Properly align the motor with the load using a flexible coupling

- Protect the motor shaft from excessive thrust, overhang and shock loads

### DESIGN TIPS

- Series connect lead wires for best torque at low speeds
- Center tap to end or parallel connect lead wires for best torque at higher speeds
- Keep motor case temperature below 100°C. This can be achieved by lowering the motor current or limiting the duty cycle

- Allow sufficient time to accelerate load
- Size motor with 100% safety factor for required torque @ speed
- Do not disassemble motors. A significant reduction in motor performance will result
- Do not disconnect motor from drive while in operation
- Do not use holding torque/ detent torque of motor as fail-safe brake

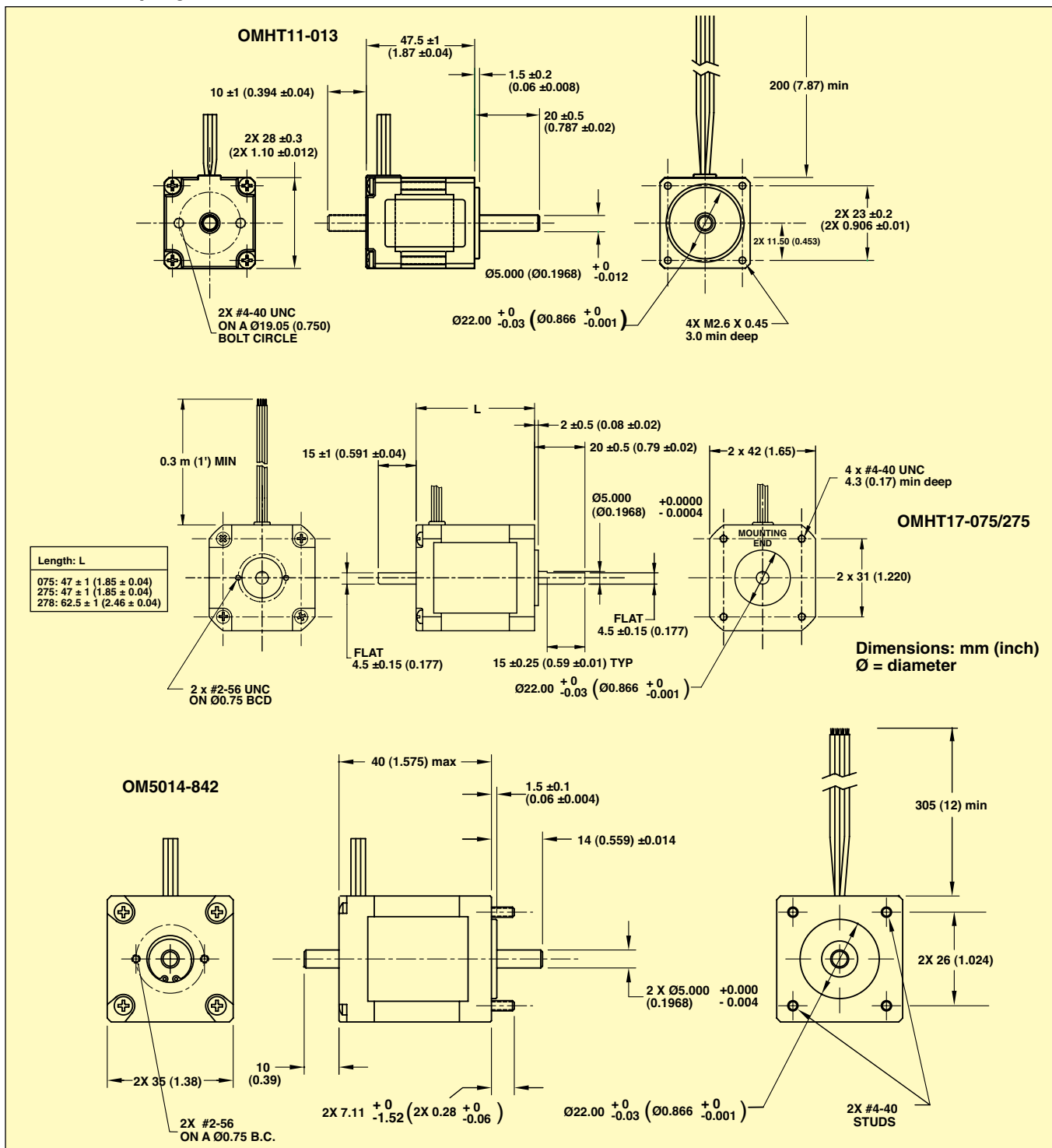



**OMHT23-393/397/400**

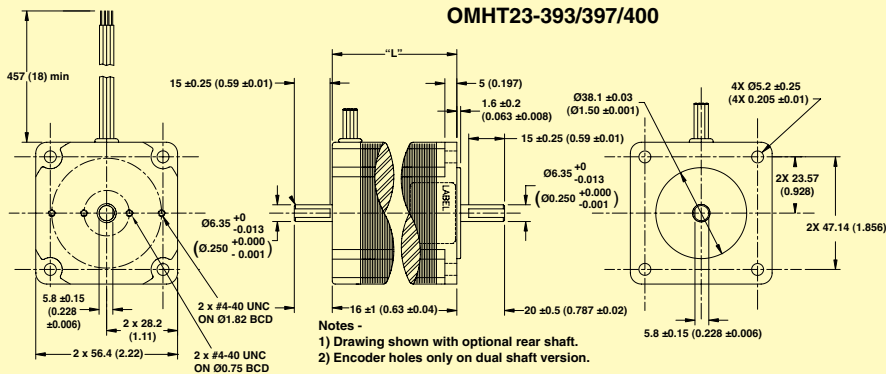

Length: L

393: 39 ± 1 (1.535 ± 0.04)
397: 54 ± 1 (2.126 ± 0.04)
400: 76 ± 1 (2.99 ± 0.04)

Notes -  
 1) Drawing shown with optional rear shaft.  
 2) Encoder holes only on dual shaft version.

**OMHT23-593/597/600/603**

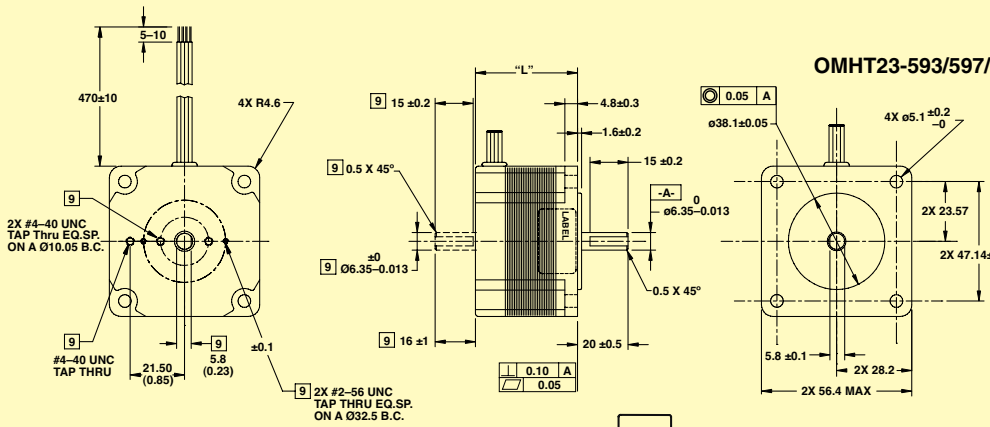

Length: L

593: 41 ± 1 (1.61 ± 0.04)
597: 54 ± 1 (2.13 ± 0.04)
600: 76 ± 1 (2.99 ± 0.04)
603: 111 ± 1 (4.37 ± 0.04)

Dimensions: mm (inch)  
 Ø = diameter

**OMHT23-550**

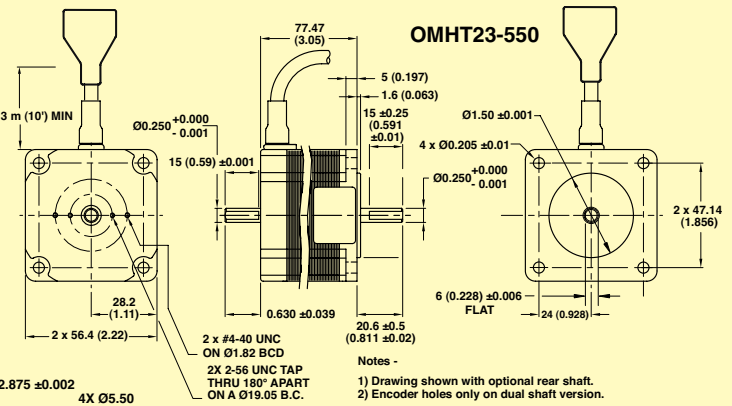

**OMHT34-485/486/487**

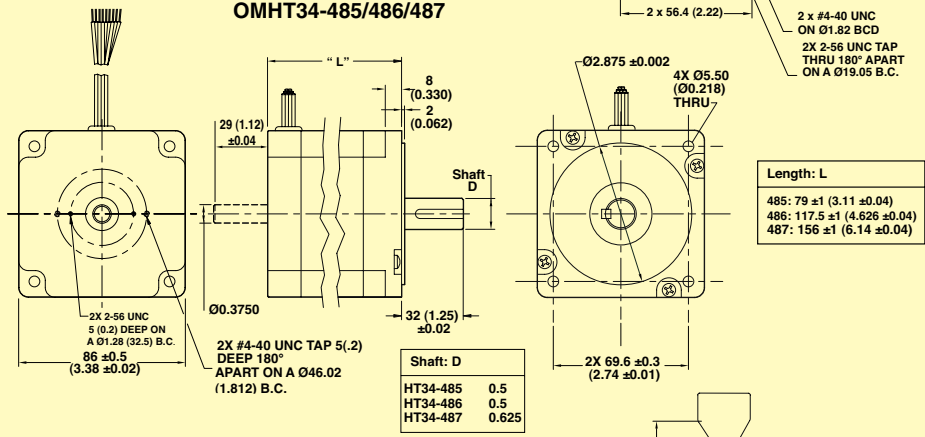

Shaft: D

HT34-485	0.5
HT34-486	0.5
HT34-487	0.625

**OMHT34-488/490**

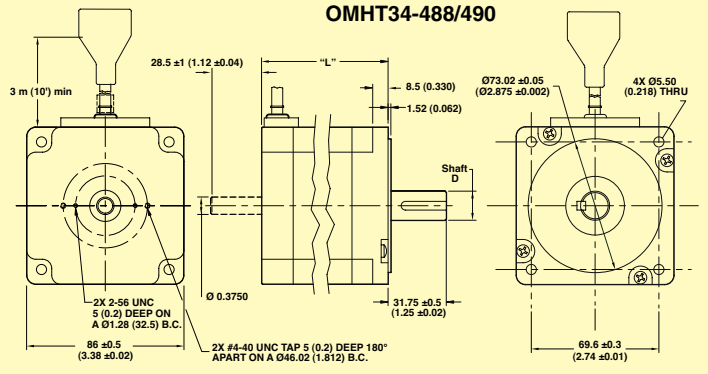

Length: L Shaft: D

488: 79 (3.11)	12.7 (0.5)
490: 155.9 (6.14)	15.875 (0.625)



OMHT24-100/105/108

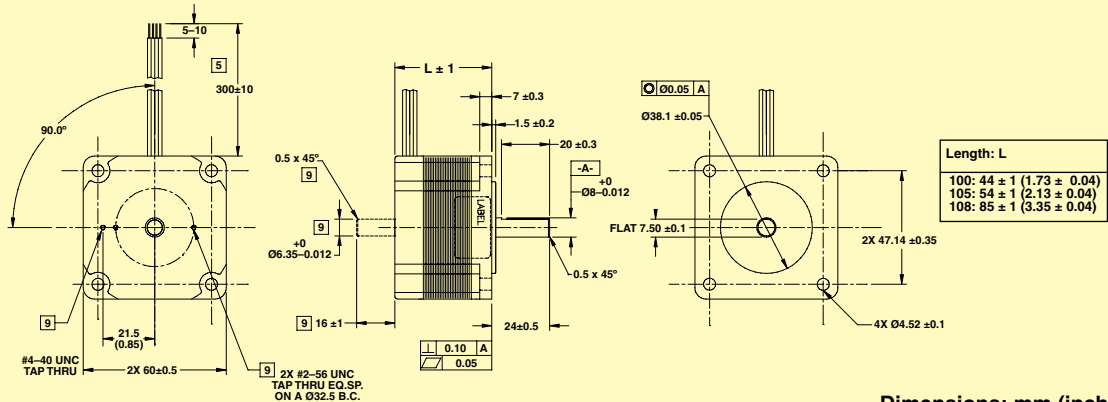

Length: L
100: 44 ± 1 (1.73 ± 0.04)
105: 54 ± 1 (2.13 ± 0.04)
108: 85 ± 1 (3.35 ± 0.04)

Dimensions: mm (inch)  
Ø = diameter

OMHT34-504/505/506

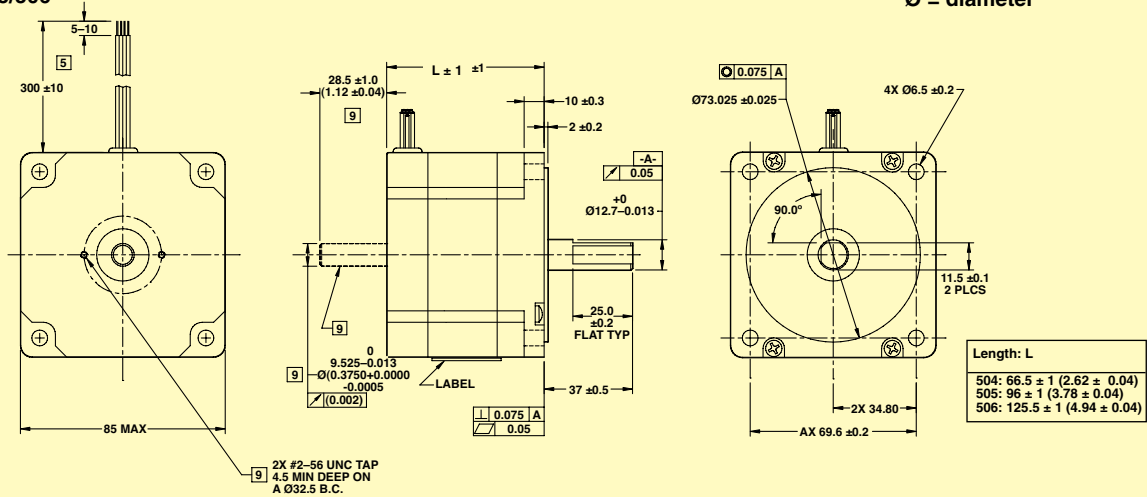

Length: L
504: 66.5 ± 1 (2.62 ± 0.04)
505: 96 ± 1 (3.78 ± 0.04)
506: 125.5 ± 1 (4.94 ± 0.04)

OPTIMAL DRIVE/MOTOR COMBINATIONS—“X” INDICATES PRIMARY MOTOR CHOICE

DRIVE													
MOTOR	1240I	2035	3540I	3540M	3540MO	SI3540	STR2	STR4	STR8	ST5-S/Si	ST10-S/Si	STAC6-S/Si	
OMHT11-013	X	X					X						
OM5014-842	X	X					X						
OMHT17-075	X	X	X	X	X	X	X			X			
OMHT17-275	X	X	X	X	X	X	X			X			
OMHT17-278	X	X	X	X	X	X		X		X			
OMHT23-393	X	X	X	X	X	X	X			X			
OMHT23-593	X	X	X	X	X	X	X			X			
OMHT23-397		X	X	X	X	X		X		X			
OMHT23-597		X	X	X	X	X		X		X			
OMHT23-400		X	X	X	X	X		X		X			
OMHT23-600		X	X	X	X	X		X		X			
OMHT23-603			X	X	X	X			X		X		
OMHT24-100			X	X	X	X		X		X			
OMHT24-105								X		X			
OMHT24-108								X		X			
OMHT34-504									X		X		
OMHT34-485									X		X		
OMHT34-505									X		X		
OMHT34-486									X		X		
OMHT34-506									X		X		
OMHT34-487									X		X		
OMHT23-550												X	
OMHT34-488												X	
OMHT34-490												X	

## RECOMMENDED MOTORS

MODEL NO.	MOTOR CONNECTION 1 = SERIES 2 = PARALLEL 3 = UNIPOLAR	MOTOR LENGTH mm (inch)	MAXIMUM HOLDING TORQUE <sup>2</sup> (oz-inch)	LEADS	STEP ANGLE (DEG)	VOLTS	AMPS	OHMS	MH	ROTOR INERTIA (oz-inch <sup>2</sup> / g-cm <sup>2</sup> )	MOTOR WEIGHT g (lb)
OMHT11-013	2	48 (1.87)	15	4	1.8	2.0	1.0	2.0	2.6	0.098/18	177 (0.39)
OM5014-842	2	40 (1.57)	26.0	4	1.8	4.8	1.0	4.3	5.5	0.109/20	213 (0.47)
OMHT17-075	1	47 (1.85)	62.8	8	1.8	5.7	0.85	6.6	12.0	0.37/68	331 (0.73)
	2		2.8			1.70	1.7	3.0			
	3		4.0			1.20	3.3	3.0			
OMHT17-275	1	48 (1.90)	62.3	8	1.8	5.7	0.85	6.6	10.0	0.44/82	357 (0.79)
	2		2.8			1.70	1.7	2.5			
	3		4.0			1.20	3.3	2.5			
OMHT17-278	1	63 (2.47)	113.0	8	1.8	6.4	1.0	6.4	12.0	0.66/121	357 (1.32)
	2		3.2			2.0	1.6	3.0			
	3		4.5			1.4	3.2	3.0			
OMHT23-393	1	39 (1.54)	76.6	8	1.8	7.4	0.71	1.7	21.6	0.66/120	454 (1.00)
	2		3.7			1.41	2.6	5.4			
	3		5.2			1.00	5.2	5.4			
OMHT23-593	1	41 (1.61)	79.3	8	1.8	7.4	0.71	10.4	26.1	0.73/135	417 (0.92)
	2		3.7			1.41	2.6	6.6			
	3		5.2			1.00	5.2	6.6			
OMHT23-397	1	54 (2.13)	177.0	8	1.8	5.1	1.41	3.6	10.0	1.64/300	699 (1.54)
	2		2.5			2.83	0.9	2.5			
	3		3.6			2.00	1.8	2.5			
OMHT23-597	1	54 (2.13)	177.0	8	1.8	5.1	1.41	3.6	10.8	1.42/260	599 (1.32)
	2		2.5			2.83	0.9	2.7			
	3		3.6			2.00	1.8	2.7			
OMHT23-400	1	76 (2.99)	264.0	8	1.8	6.4	1.41	4.5	14.4	2.62/480	998 (2.20)
	2		3.2			2.83	1.1	3.6			
	3		4.5			2.00	2.3	3.6			
OMHT23-600	1	76 (2.99)	264.8	8	1.8	6.4	1.41	4.5	15.6	2.51/460	998 (2.20)
	2		3.2			2.83	1.1	3.9			
	3		4.5			2.00	2.3	3.9			
OMHT23-603	1	111 (4.37)	354	8	1.8	5.0	2.5	2.0	8.8	4.02/735	1497 (3.30)
	2		2.5			5.0	0.5	2.2			
	3		4.5			2.00	2.25	3.8			
OMHT23-550 <sup>1</sup>	1	78 (3.05)	255.0	8	1.8	6.3	1.41	4.5	15.2	7.8/1400 2.62/480	998 (2.20)
	2		3.2			2.83	1.13	3.8			
	3		4.5			2.00	2.25	3.8			
OMHT24-100	2	44 (1.73)	123	4	1.8	2.0	2.8	0.73	1.6	1.42/260	599 (1.32)
OMHT24-105	2	54 (2.13)	177	4	1.8	1.7	4.0	0.43	1.1	2.46/450	830 (1.83)
OMHT24-108	2	85 (3.35)	354	4	1.8	2.6	4.0	0.65	2.4	4.91/900	1402 (3.09)
OMHT34-504	1	66 (2.62)	396	8	1.8	3.05	3.18	0.96	6.8	6.0/1100	1588 (3.5)
	2		1.51			6.3	0.24	1.7			
	3		2.16			4.5	0.48	1.7			
OMHT34-485	1	79 (3.11)	650	8	1.8	3.2	4.3	0.76	5.2	7.8/1400	2803 (6.18)
	2		1.6			8.6	0.19	1.3			
	3		2.26			6.0	0.38	1.3			
OMHT34-505	1	96 (3.78)	849	8	1.8	4.20	3.18	1.32	10.8	10.1/1850	2676 (5.9)
	2		2.08			6.3	0.33	2.7			
	3		2.97			4.5	0.66	2.7			
OMHT34-486	1	118 (4.63)	1200	8	1.8	4.4	4.1	1.08	8.8	14.6/2680	3810 (8.40)
	2		2.2			8.1	0.27	2.2			
	3		3.1			5.7	0.54	2.2			
OMHT34-506	1	125 (4.94)	1260	8	1.8	5.43	2.8	1.94	21.6	15.0/2750	3810 (8.4)
	2		2.74			5.6	0.49	5.4			
	3		3.88			4.0	0.97	5.4			



All models shown smaller than actual size.

## RECOMMENDED MOTORS (CONTINUED)

MODEL NO.	MOTOR CONNECTION 1 = SERIES 2 = PARALLEL 3 = UNIPOLAR	MOTOR LENGTH mm (inch)	MAXIMUM HOLDING TORQUE <sup>2</sup> (oz-inch)	LEADS	STEP ANGLE (DEG)	VOLTS	AMPS	OHMS	MH	ROTOR INERTIA (oz-inch <sup>2</sup> / g-cm <sup>2</sup> )	MOTOR WEIGHT g (lb)
OMHT34-487	1	156 (6.14)	1845	8	1.8	4.8	4.5	1.08	9.6	21.9/4000	5398 (11.9)
	2		2.4			9.0	0.27	2.4			
	3		3.4			6.3	0.54	2.4			
OMHT34-488 <sup>1</sup>	1	79 (3.11)	650	8	1.8	3.2	4.3	1.6	5.2	7.8/1400	3629 (8.00)
	2		1.6			8.6	0.4	1.3			
	3		2.26			6.0	0.8	1.3			
OMHT34-490 <sup>1</sup>	1	156 (6.14)	1845	8	1.8	4.5	4.8	1.7	9.6	21.9/4000	5398 (11.9)
	2		2.25			9.6	0.42	2.4			
	3		3.2			6.8	0.85	2.4			

<sup>1</sup> Motor with 3 m (10') shielded cable.

<sup>2</sup> Guaranteed minimum holding torque; actual torque may be 5 to 10% greater.

All size 17 through 34 motors are optimized for microstepping. Model numbers listed are for single shaft. To order double shaft add "-D" to the end of the model number for additional cost.

Ordering Example: OMHT23-393-D, NEMA 23 high torque step motor with double shaft.

## MECHANICAL AND ELECTRICAL SPECIFICATIONS

	SIZE 11	SIZE 14	SIZE 17	SIZE HT17	SIZE 23	SIZE HT23	SIZE 34	SIZE HT34
SHAFT RUN-OUT mm (inch)	0.01 (0.0005)	0.01 (0.0005)	0.01 (0.0005)	0.01 (0.0005)	0.03 (0.001)	0.05 (0.002)	0.05 (0.002)	0.05 (0.002)
RADIAL PLAY (inch/lb)	0.001 max @ 1.1 lb	0.0004 max @ 1 lb	0.001 max @ 1 lb	0.001 max @ 1 lb	0.001 max @ 1 lb	0.001 max @ 1 lb	0.001 max @ 1 lb	0.001 max @ 1 lb
END PLAY (inch/lb)	0.003 max @ 2.2 lb	0.0004 max @ 2 lb	0.001 max @ 3 lb	0.003 max @ 2.2 lb	0.003 max @ 2.2 lb	0.003 max @ 2.2 lb	0.001 max @ 15 lb	0.003 max @ 2.2 lb
PERPENDICULARITY	0.002	0.003	0.003	0.003	0.003	0.003	0.003	0.003
CONCENTRICITY mm (inch)	0.05 (0.002)	0.05 (0.002)	0.05 (0.002)	0.05 (0.002)	0.05 (0.002)	0.05 (0.002)	0.05 (0.002)	0.05 (0.002)
OPERATING TEMPERATURE RANGE	-20 to 50°C (-4 to 122°F)	-20 to 50°C (-4 to 122°F)	-20 to 50°C (-4 to 122°F)	-20 to 50°C (-4 to 122°F)	-20 to 50°C (-4 to 122°F)	-20 to 50°C (-4 to 122°F)	-20 to 50°C (-4 to 122°F)	-20 to 50°C (-4 to 122°F)
INSULATION CLASS	130°C (266°F) Class B	130°C (266°F) Class B	130°C (266°F) Class B	130°C (266°F) Class B	130°C (266°F) Class B	130°C (266°F) Class B	130°C (266°F) Class B	130°C (266°F) Class B
LEAD WIRE GAGE	26 AWG	26 AWG	22 AWG	26 AWG	22 AWG	22 AWG	18 AWG	22 AWG
MAX RADIAL LOAD g (lb)	2268 (5)	2268 (5)	2268 (5)	2268 (5)	6804 (15)	6804 (15)	11340 (25)	11340 (25)
MAX THRUST LOAD g (lb)	1361 (3)	1361 (3)	1361 (3)	1361 (3)	11340 (25)	11340 (25)	22680 (50)	22680 (50)



**To Order** Visit [omega.com/omht\\_series](http://omega.com/omht_series) for Pricing and Details

MODEL NO.	DESCRIPTION
OMHT11-013	NEMA 11 high torque step motor, 15 oz-in holding torque
OM5014-842	NEMA 14 standard torque step motor, 26 oz-in holding torque
OMHT17-075	NEMA 17 high torque step motor, 62.8 oz-in holding torque
OMHT17-275	NEMA 17 high torque step motor, 62.3 oz-in holding torque
OMHT17-278	NEMA 17 high torque step motor, 113 oz-in holding torque
OMHT23-393	NEMA 23 high torque step motor, 76.6 oz-in holding torque
OMHT23-593	NEMA 23 high torque step motor, 79.3 oz-in holding torque
OMHT23-397	NEMA 23 high torque step motor, 177 oz-in holding torque
OMHT23-597	NEMA 23 high torque step motor, 177 oz-in holding torque
OMHT23-400	NEMA 23 high torque step motor, 264 oz-in holding torque
OMHT23-600	NEMA 23 high torque step motor, 264.8 oz-in holding torque
OMHT23-603	NEMA 23 high torque step motor, 354 oz-in holding torque
OMHT24-100	NEMA 24 high torque step motor with, 123 oz-in holding torque
OMHT24-105	NEMA 24 high torque step motor with, 177 oz-in holding torque
OMHT24-108	NEMA 24 high torque step motor with, 354 oz-in holding torque
OMHT34-504	NEMA 34 high torque step motor, 396 oz-in holding torque
OMHT34-485	NEMA 34 high torque step motor, 650 oz-in holding torque
OMHT34-505	NEMA 34 high torque step motor, 849 oz-in holding torque
OMHT34-486	NEMA 34 high torque step motor, 1200 oz-in holding torque
OMHT34-506	NEMA 34 high torque step motor, 1260 oz-in holding torque
OMHT34-487	NEMA 34 high torque step motor, 1845 oz-in holding torque

**MOTORS FOR STAC6 DRIVE: SHIELDED CABLE AND CONNECTOR**

MODEL NO.	DESCRIPTION
OMHT23-550	NEMA 23 high torque step motor with 3 m (10') shielded cable, 255 oz-in holding torque
OMHT34-488	NEMA 34 high torque step motor with 3 m (10') shielded cable, 650 oz-in holding torque
OMHT34-490	NEMA 34 high torque step motor with 3 m (10') shielded cable, 1845 oz-in holding torque

**ACCESSORIES**

MODEL NO.	DESCRIPTION
ENC-1000i	Differential encoder for NEMA 11/14/17 motors, 1000-line, with index pulse
ENC-1000i-23	Differential encoder for NEMA 23/24 motors, 1000-line, with index pulse
ENC-1000i-34	Differential encoder for NEMA 34 motors, 1000-line, with index pulse
ENC-CA-4217-6FT	Encoder cable, 2 m (6')
ENC-CA-4217-10FT	Encoder cable, 3 m (10')
ENC-CA-4217-20FT	Encoder cable, 6 m (20')
ENC-ZAA	Differential encoder for ST and STAC6 drives, NEMA 23/24 motors, 2000-line, with index
ENC-YAA	Differential encoder for ST and STAC6 drives, NEMA 34 motors, 2000-line, with index
ENC-ST-CA-10	Encoder cable for ST and STAC6 drives, 3 m (10')

Encoders offered are differential encoders with line drivers. These provide two channels of signals with complementary signals. Versions with index also offer Z-channel and its complementary signal. Remember that a double shaft motor is required.

**Ordering Examples:** OMHT17-075-D NEMA 17 high torque step motor with 62.8 oz-in min holding torque and double shaft.

ENC-1000i 1000-line encoder with index pulse for NEMA 17 motor, and ENC-CA-4217-10FT 3 m (10') encoder cable.

**ST/STAC6 Encoder Option:**

Use encoder ENC-ZAA for ST5-Si, ST10-Si, and STAC6-Si drives with NEMA 23 motors.

Use encoder ENC-YAA for ST5-Si, ST10-Si, and STAC6-Si drives with NEMA 34 motors.

The ENC-ST-CA-10 cable connects the optional encoders listed above to the ST and STAC6 series drives.