

THE THERMISTOR

Like the RTD, the thermistor is also a temperature sensitive resistor. While the thermocouple is the most versatile temperature transducer and the PRTD is the most stable, the word that best describes the thermistor is *sensitive*. Of the three major categories of sensors, the thermistor exhibits by far the largest parameter change with temperature.

Thermistors are generally composed of semiconductor materials. Although positive temperature coefficient units are available, most thermistors have a negative temperature coefficient (TC); that is, their resistance decreases with increasing temperature. The negative T.C. can be as large as several percent per degree Celsius, allowing the thermistor circuit to detect minute changes in temperature which could not be observed with an RTD or thermocouple circuit.

The price we pay for this increased sensitivity is loss of linearity. The thermistor is an extremely non-linear device which is highly dependent upon process parameters. Consequently, manufacturers have not standardized thermistor curves to the extent that RTD and thermocouple curves have been standardized.

An individual thermistor curve can be very closely approximated through use of the Steinhart-Hart equation:¹⁸

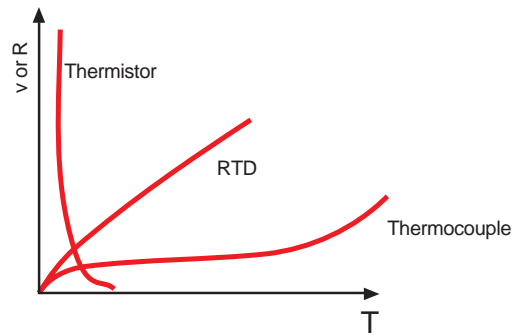

Figure 47

$$\frac{1}{T} = A + B \ln R + C (\ln R)^3$$

where:

T = Degrees Kelvin

R = Resistance of the thermistor

A, B, C = Curve-fitting constants

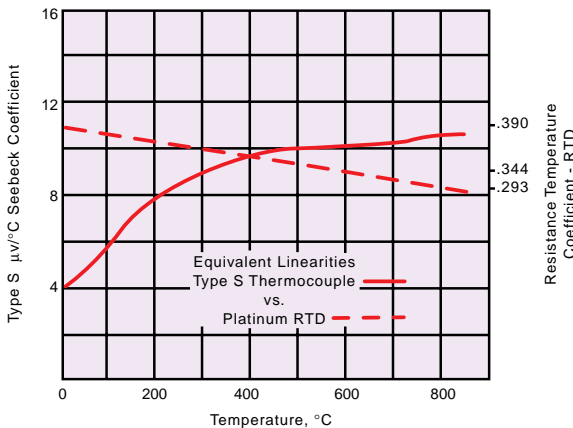

Figure 46

Practical Precautions

The same practical precautions that apply to thermocouples also apply to RTD's, *i.e.*, use shields and twisted-pair wire, use proper sheathing, avoid stress and steep gradients, use large extension wire, keep good documentation and use a guarded integrating dvm. In addition, the following precautions should be observed.

Construction - Due to its construction, the RTD is somewhat more fragile than the thermocouple, and precautions must be taken to protect it.

Self-Heating - Unlike the thermocouple, the RTD is not self-powered. A current must be passed through the device to provide a voltage that can be measured. The current causes Joule (I^2R) heating within the RTD, changing its temperature. This *self-heating* appears as a measurement error. Consequently, attention must be paid to the magnitude of the measurement current supplied by the ohmmeter. A typical value for self-heating error is $\frac{1}{2}^\circ\text{C}$ per milliwatt in free air. Obviously, an RTD immersed in a thermally conductive medium will distribute its Joule heat to the medium, and the error due to self-heating will be smaller. The same RTD that rises 1°C per milliwatt in free air will rise only $\frac{1}{10}^\circ\text{C}$ per milliwatt in air which is flowing at the rate of one meter per second.¹⁰

To reduce self-heating errors, use the minimum ohms measurement current that will still give the resolution you require, and use the largest RTD you can that will still give good response time. Obviously, there are compromises to be considered.

Thermal Shunting - Thermal shunting is the act of altering the measurement temperature by inserting a measurement transducer. Thermal shunting is more a problem with RTD's than with thermocouples, as the physical bulk of an RTD is greater than that of a thermocouple.

Small RTD	Large RTD
Fast Response Time	Slow Response Time
Low Thermal Shunting	Poor Thermal Shunting
High Self-Heating Error	Low Self-Heating Error

Thermal EMF - The platinum-to-copper connection that is made when the RTD is measured can cause a thermal offset voltage. The offset-compensated ohms technique can be used to eliminate this effect.

¹⁰ Refer to Bibliography 6.

A, B, and C are found by selecting three data points on the published data curve and solving the three simultaneous equations. When the data points are chosen to span no more than 100°C within the nominal center of the thermistor's temperature range, this equation approaches a rather remarkable $\pm 0.02^\circ\text{C}$ curve fit.

Somewhat faster computer execution time is achieved through a simpler equation:

$$T = \frac{B}{\ln R - A} - C$$

where A, B, and C are again found by selecting three (R,T) data points and solving the three resultant simultaneous equations. This equation must be applied over a narrower temperature range in order to approach the accuracy of the Steinhart-Hart equation.

Linear Thermistors

A great deal of effort has gone into the development of thermistors which approach a linear characteristic. These are typically 2- or 4-leaded devices requiring external matching resistors to linearize the characteristic curve. The modern data acquisition system with its computing controller has made this kind of hardware linearization unnecessary.

Measurement

The high resistivity of the thermistor affords it a distinct measurement advantage. The four-wire resistance measurement is not required as it is with RTD's. For example, a common thermistor value is 5000 ohms at 25°C. With a typical T.C. of 4%/°C, a measurement lead resistance of 100 produces only a .05°C error. This error is a factor of 500 times less than the equivalent RTD error.

Disadvantages - Because they are semiconductors, thermistors are more susceptible to permanent decalibration at high temperatures than are RTD's or thermocouples. The use of thermistors is generally limited to a few hundred degrees Celsius and manufacturers warn that extended exposures even well below maximum operating limits will cause the thermistor to drift out of its specified tolerance.

Thermistors can be made very small which means they will respond quickly to temperature changes. It also means that their small thermal mass makes them especially susceptible to self-heating errors.

Thermistors are a good deal more fragile than RTD's or thermocouples and they must be carefully mounted to avoid crushing or bond separation.

MONOLITHIC LINEAR TEMPERATURE SENSOR

A recent innovation in thermometry is the integrated circuit temperature transducer. It is available in both voltage and current-output configurations. Both supply an output that is linearly proportional to absolute temperature. Typical values are 1 $\mu\text{A}/\text{K}$ and 10 mV/K.

Except for the fact that they offer a very linear output with temperature, these devices share all the disadvantages of thermistor devices and thus have a limited temperature range. The same problems of self-heating and fragility are evident, and they require an external power source.

These devices provide a convenient way to produce an analog voltage proportional to temperature. Such a need arises in a hardware thermocouple reference junction compensation circuit (see Figure 15).

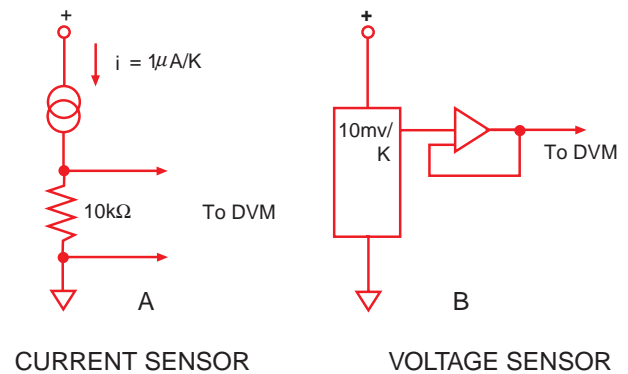

Figure 48

APPENDIX A The Empirical Laws of Thermocouples¹¹

The following examples illustrate the empirically derived "laws" of thermocouples which are useful in understanding and diagnosing thermocouple circuits.

¹¹ Refer to Bibliography 2.

APPENDIX B Thermocouple Characteristics

Over the years, specific pairs of thermocouple alloys have been developed to solve unique measurement problems. Idiosyncrasies of the more common thermocouples are discussed here.

We will use the term *standard wire error* to refer to the common commercial specifications published in the *Annual Book of ASTM Standards*. It represents the allowable deviation between the actual thermocouple output voltage and the voltage predicted by the tables in NBS Monograph 125.

Noble Metal Thermocouples - The noble metal thermocouples, types B, R, and S, are all platinum or platinum-rhodium thermocouples and hence share many of the same characteristics.

Diffusion - Metallic vapor diffusion at high temperatures can readily change platinum wire calibration; therefore, platinum wires should only be used inside a *non-metallic* sheath such as high-purity alumina. The one exception to this rule is a sheath made of platinum, but this option is prohibitively expensive.

Stability - The platinum-based couples are by far the most stable of all the common thermocouples. Type S is so stable that it is specified as the standard for temperature calibration between the antimony point (630.74°C) and the gold point (1064.43°C).

Type B - The B couple is the only common thermocouple that exhibits a double-valued ambiguity.

Due to the double-valued curve and the extremely low Seebeck coefficient at low temperatures, Type B is virtually useless below 50°C. Since the output is nearly zero from 0°C to 42°C, Type B has the unique advantage that the *reference* junction temperature is almost immaterial, as long as it is between 0° and 40°C. Of course, the *measuring* junction temperature is typically very high.

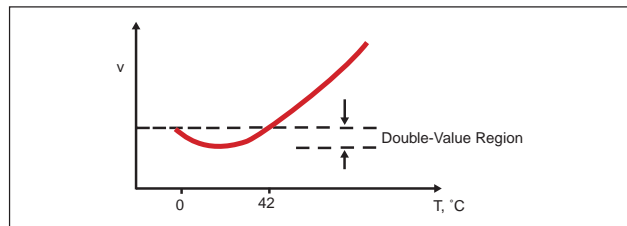

Base Metal Thermocouples

Unlike the noble metal thermocouples, the base metal couples have no specified chemical composition. Any combination of metals can be used which results in a voltage vs. temperature curve fit that is within the standard wire errors. This leads to some rather interesting metal combinations. *Constantan*, for example, is not a specific metal alloy at all, but a generic name for a whole series of copper-nickel alloys. Incredibly, the *Constantan* used in a type T (copper-Constantan) thermocouple is not the same as the *Constantan* used in the type J (iron-Constantan) couple.¹²

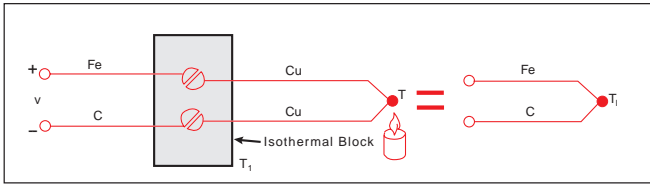

THE LAW OF INTERMEDIATE METALS

Inserting the copper lead between the iron and constantan leads will not change the output voltage V , regardless of the temperature of the copper lead. The voltage V is that of an Fe-C thermocouple at temperature T_1 .

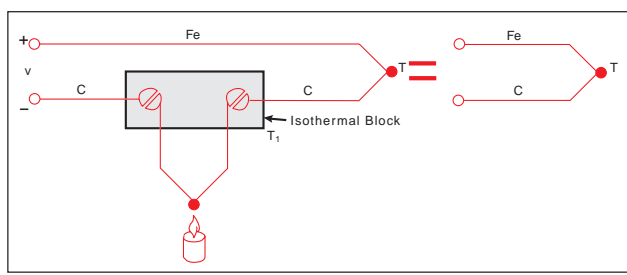

THE LAW OF INTERIOR TEMPERATURES

The output voltage V will be that of an Fe-C couple at Temperature T , regardless of the external heat source applied to either measurement lead.

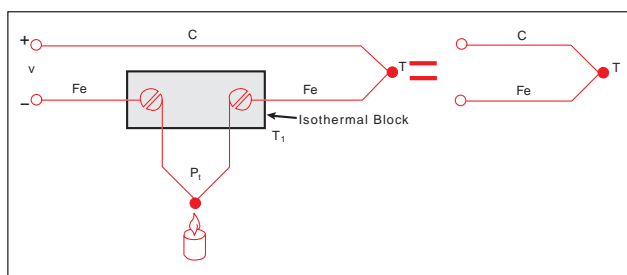

THE LAW OF INSERTED METALS

The voltage V will be that of an Fe-C thermocouple at temperature T , provided both ends of the platinum wire are at the same temperature. The two thermocouples created by the platinum wire (FePt and Pt-Fe) act in opposition.

All of the above examples assume the measurement wires are homogeneous; that is, free of defects and impurities.

¹² Refer to Bibliography 3

Type E - Although Type E standard wire errors are not specified below 0°C, the type E thermocouple is ideally suited for low temperature measurements because of its high Seebeck coefficient (58 $\mu\text{V}/^\circ\text{C}$), low thermal conductivity and corrosion resistance.

The Seebeck coefficient for Type E is greater than all other standard couples, which makes it useful for detecting small temperature changes.

Type J - Iron, the positive element in a J couple, is an inexpensive metal rarely manufactured in pure form. J thermocouples are subject to poor conformance characteristics because of impurities in the iron. Even so, the J couple is popular because of its high Seebeck coefficient and low price.

The J couple should never be used above 760°C due to an abrupt magnetic transformation that can cause decalibration even after the instrument cools.

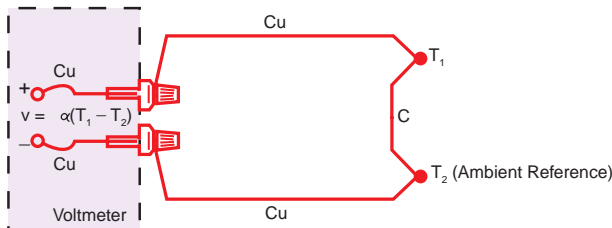

TYPE T

Type T - This is the only couple with published standard wire errors for the temperature region below 0°C; however, type E is actually more suitable at very low temperatures because of its higher Seebeck coefficient and lower thermal conductivity.

Type T has the unique distinction of having one copper lead. This can be an advantage in a specialized monitoring situation where a temperature difference is all that is desired.

The advantage is that the copper thermocouple leads are the same metal as the dvm terminals, making lead compensation unnecessary.

Types K & Nicrosil-Nisil - The Nicrosil-Nisil thermocouple, type N, is similar to type K, but it has been designed to minimize some of the instabilities in the conventional Chromel-Alumel combination. Changes in the alloy content have improved the order/disorder transformations occurring at 500°C, and a higher silicon content in the positive element improves the oxidation resistance at elevated temperatures. A full description with characteristic curves is published in NBS Monograph 161.¹³

Tungsten - Tungsten-rhenium thermocouples are normally used at high temperature in reducing or vacuum environments, but never in an oxidizing atmosphere because of the high reaction rates. Pure tungsten becomes very brittle when heated above its recrystallization temperature (about 1200°C). To make the wire easier to handle, rhenium alloys are used in both thermocouple legs. Types G (tungsten vs. tungsten 26% rhenium), C (tungsten 5% rhenium vs. tungsten 26% rhenium) and D (tungsten 3% rhenium vs. tungsten 25% rhenium) thermocouples are available in bare wire forms as well as complete probe assemblies. All materials conform to published Limits of Error. 

ASTM STANDARD WIRE ERRORS¹⁴

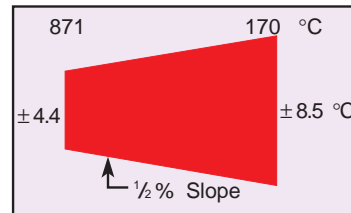

TYPE B 24 AWG

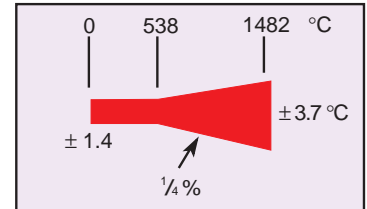

TYPE R,S 24 AWG

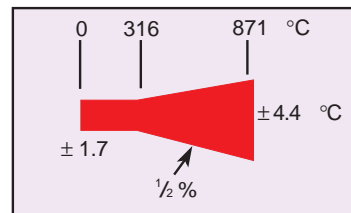

TYPE E 8 AWG

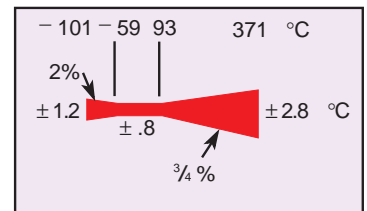

TYPE T 14 AWG

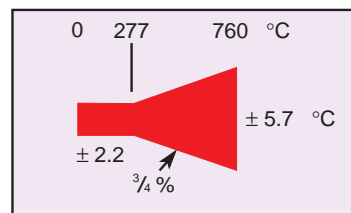

TYPE J 8 AWG

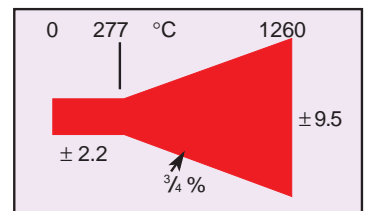

TYPE K 8 AWG

At high temperatures, small thermocouple wire is affected by diffusion, impurities, and inhomogeneity more so than large wire. The standard wire errors reflect this relationship.

Note that each NBS wire error specification carries with it a wire size. The noble metal thermocouples (B, R, and S) are specified with small (24 ga.) wire for obvious cost reasons.

¹³ Refer to Bibliography 14.

¹⁴ Refer to Bibliography 3.

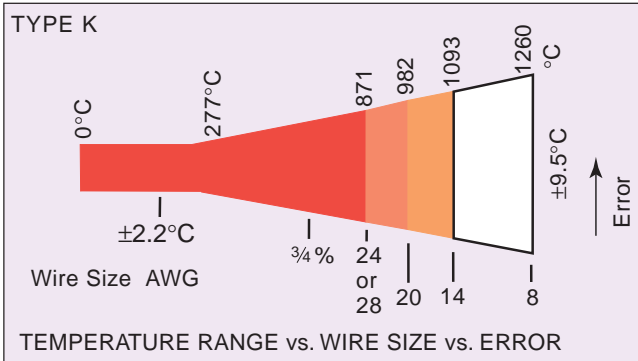

AWG	DIA, MILS	DIA, mm
8	128	3.3
10	102	2.6
12	81	2.1
14	64	1.6
16	51	1.3
18	40	1
20	32	0.8
22	25	0.6
24	20	0.5
26	16	0.4
28	13	0.3

TYPE	METAL		STANDARD COLOR CODE + -	Ω/DOUBLE FOOT 20 AWG	SEEBECK COEFFICIENT S(μV/°C) @ T (°C)		°C STANDARD WIRE ERROR (SEE APPENDIX B)	NBS SPECIFIED MATERIAL RANGE† (°C)
	+	-						
B	Platinum - 6% Rhodium	Platinum - 30% Rhodium	-	0.2	6	600	4.4 to 8.6	0 to 1820*
E	Nickel - 10% Chromium	Constantan	Violet Red	0.71	58.5	0	1.7 to 4.4	-270 to 1000
J	Iron	Constantan	White Red	0.36	50.2	0	1.1 to 2.9	-210 to 760
K	Nickel - 10% Chromium	Nickel	Yellow Red	0.59	39.4	0	1.1 to 2.9	-270 to 1372
N (AWG 14)	Nicrosil	Nisil	-	-	39	600	-	0 to 1300
N (AWG 28)	Nicrosil	Nisil	-	-	26.2	0	-	-270 to 400
R	Platinum-13% Rhodium	Platinum	-	0.19	11.5	600	1.4 to 3.8	-50 to 1768
S	Platinum - 10% Rhodium	Platinum	-	0.19	10.3	600	1.4 to 3.8	-50 to 1768
T	Copper	Constantan	Blue Red	0.30	38	0	0.8 to 2.9	-270 to 400
W-Re	Tungsten - 5% Rhenium	Tungsten - 26% Rhenium	-	-	19.5	600	-	0 to 2320

* Type B double-valued below 42°C - curve fit specified only above 130°C
 † Material range is for 8 AWG wire; decreases with decreasing wire size

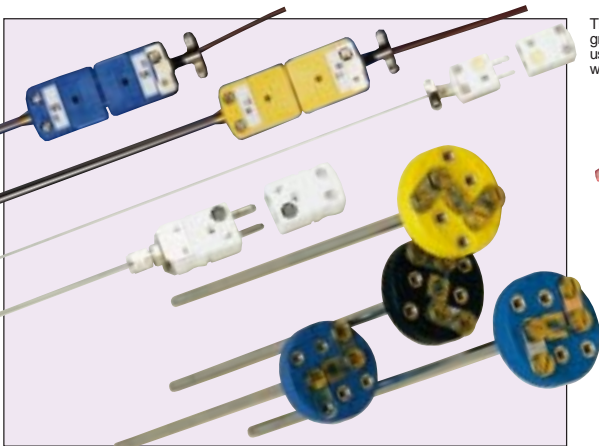

Connector: Composed of same metals as thermocouple, for minimum connection error.

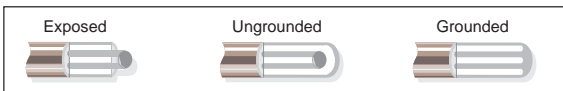

Exposed Junction: Wires unprotected, faster response.
 Ungrounded Junction: Best protection, electronically isolated.
 Grounded Junction: Wires protected, faster response.

Thermocouple Washers:
 Couple built into washer,
 convenient mounting.



Thermocouple Well: Lower gradient, protects wire and allows user to change thermocouple without interrupting process.



BIBLIOGRAPHY

- Charles Herzfeld, F.G. Brickwedde: *Temperature - Its Measurement and Control in Science and Industry*, Vol. 3, Part 1, Reinhold, New York, 1962.
- Robert P. Benedict: *Fundamentals of Temperature, Pressure and Flow Measurements*, John Wiley & Sons, Inc., New York, 1969.
- Manual on the Use of Thermocouples in Temperature Measurement*, ASTM Special Publication 470A, Omega Press, Stamford, Connecticut 06907, 1974.
- Thermocouple Reference Tables*, NBS Monograph 125, National Bureau of Standards, Washington, D.C., 1979. Also, *Temperature-Millivolt Reference Tables-Section T*, Omega Temperature Measurement Handbook, Omega Press, Stamford Connecticut 06907, 1983.
- H. Dean Baker, E.A. Ryder, N.H. Baker: *Temperature Measurement in Engineering*, Omega Press, Stamford, Connecticut 06907, 1953.
- Temperature Measurement Handbook*, Omega Engineering, Inc., Stamford, Connecticut.
- R.L. Anderson: *Accuracy of Small Diameter Sheathed Thermocouples for the Core Flow Test Loop*, Oak Ridge National Laboratories, ORNL-54011 (available from National Information Service), April, 1979.
- R. R. Reed: *Branched Thermocouple Circuits in Underground Coal Gasification Experiments*, Proceedings of the 22nd ISA International Instrumentation Symposium, Instrument Society of America, 1976.
- R. J. Moffat: *The Gradient Approach to Thermocouple Circuitry*, from *Temperature - Its Measurement and Control in Science and Industry*, Reinhold, New York, 1962.
- R.P. Reed: *A Diagnostics-Oriented System for Thermocouple Thermometry*, Proceedings of 24th ISA International Instrumentation Symposium, Instrument Society of America, 1978.
- Harry R. Norton: *Handbook of Transducers for Electronic Measuring Systems*, Prentice-Hall, Englewood Cliffs, New Jersey.
- C.H. Meyers: *Coiled Filament Resistance Thermometers*, NBS Journal of Research, Vol. 9, 1932.
- Bulletin 9612, Rev. B: *Platinum Resistance Temperature Sensors*, Rosemount Engineering Co., 1962.
- Burley, Powell, Burns & Scroger: *The Nicrosil vs. Nisil Thermocouple: Properties and Thermoelectric Reference Data*, NBS Monograph 161, U.S. Dept. of Commerce, Washington, D.C., 1978.
- J.P. Tavener: *Platinum Resistance Temperature Detectors - State of the Art*, Measurements & Control, Measurements & Data Corporation, Pittsburgh, PA., April, 1974.
- J.P. Evans and G.W. Burns: *A Study of Stability of High Temperature Platinum Resistance Thermometers, in Temperature - Its Measurement and Control in Science and Industry*, Reinhold, New York, 1962.
- D.D. Pollock: *The Theory and Properties of Thermocouple Elements*, ASTM STP 492, Omega Press, Stamford, Connecticut 06907, 1979.
- YSI *Precision Thermistors*, Yellow Springs Instruments, Yellow Springs, Ohio, 1977.

* Hewlett Packard Company makes no warranty as to the accuracy or completeness of the foregoing material and disclaims any responsibility therefor. (Editor's Note: Thermocouple data which conform to ITS-90 are given in "ITS-90 Thermocouple Direct and Inverse Polynomials.")

OMEGA ENGINEERING, INC. gratefully acknowledges the HEWLETT PACKARD COMPANY for permission to reproduce **Application Note 290-Practical Temperature Measurements.**